

# **SRI PADMAVATI MAHILA VISVAVIDYALAYAM**

(Women's University)

**Accredited by NAAC with "A" grade ISO9001:2015 CERTIFIED**



## **CAREER COUNSELLING & GUIDANCE ACTIVITIES 2020-21**

<b>Program No</b>	<b>01</b>
<b>Name of the program</b>	Virtual Company specific Training Program
<b>Date</b>	15 <sup>th</sup> October 2020 to 17 <sup>th</sup> October 2020
<b>Venue</b>	Virtual Mode
<b>Total No of Students</b>	320
<b>Report</b>	<p>Organised Virtual company specific training program for CTS drive, by Xplore, Aceline Tech solutions for B.Tech, M.Tech &amp; MCA final year students. It has helped the students to understand CTS recruitment pattern and prepare for the drive accordingly. The Trainers has covered the below mention topics</p> <p>Topics</p> <ol style="list-style-type: none"> <li>1. Auto-proctored Test</li> <li>2. Quants</li> <li>3. Logical Reasoning</li> <li>4. Coding/Debugging</li> <li>5. Verbal/Essay Writing</li> <li>6. Technical and HR Interviews Skills</li> </ol>

**Circular**



GoToMeeting  
Talking: sahya narayana

View Everyone

1771026 Harika Gundra to Everyone  
20

2018MCA16046-Sheik Rehana-SPMVV to Everyone  
21

1771026 Harika Gundra to Everyone  
-32

2018MCA16046-Sheik Rehana-SPMVV to Everyone  
ch-32

```

#include<stdio.h>
void main()
{
    int i = 5;
    int a = ++i + ++i + ++i + ++i;
    printf("%d", a);
}

```

Output:  
30

Modify the code so that we can get expected output as : 31

**QUESTION 21**

You are required to fix all logical errors in the given code. You can click on Compile & Run anytime to check the compilation/execution status of the program. You can use printf() to debug your code. The submitted code should be logically/syntactically correct and pass all testcases. Do not write the main() function as it is not required. Code Approach: For this question, you will need to correct the given implementation. We do not expect you to modify the approach or incorporate any additional library methods. The following code will compile successfully but there is logical error. Look the code and modify so that we can get respective output.

## Virtual Training Sessions

GoToMeeting  
Talking: Shaik Salman

View Everyone

115

Skalya -Me  
Sri Venela  
SUPRAJA  
Sushmitha thappeta  
SwathiJ  
Teja Sripathi  
Tejasri  
Tetala Lakshmi Mounika  
Vana Gayatri Mylapally  
Vishnu Vandana Kona (1772...  
Yamini  
Yennu Devi

MEETING ID: 321-492-673

Go To Settings Copy Meeting Link

Shaik Salman's presentation

Type here to search

GoToMeeting  
Talking: sahya narayana

View Everyone

220

Shaik Salman (Org)  
-katti Aruna  
1  
176016  
1771009 - Chinmayisree S...  
1771021-Vemulakonda Go...  
1771022 D.Gowthari Spmv  
1771026 Harika Gundra  
1771029-MHimmasri Sai-Sri...  
1771035 mkavya Spmv  
1771038-Konuru Lakshmi L...  
1771050 - Monisha priya N...

MEETING ID: 855-499-253

Copy Meeting Link

**QUESTION 4**

Sample Input1:  
4 30

Sample Output1:  
11

Sample Input2:  
101 20

Sample Output2:  
1

*R. Usha*  
Co ordinator  
Career and Counselling cell  
UGC  
Sri Padmavati Mahila Visvavidyalayan  
TIRUPATI - 617 602

<b>Program No</b>	<b>02</b>
<b>Name of the program</b>	Virtual Company Specific Training Program for TCS
<b>Date</b>	20 <sup>th</sup> October 2020 to 23 <sup>rd</sup> October 2020
<b>Venue</b>	Virtual mode
<b>Total No of Students</b>	328
<b>Report</b>	<p>Organised Virtual Company Specific training program by Packet Prep for B.Tech, M.Tech and MCA final year students in order to prepare themselves for TCS recruitment. During the training program, the trainers has discussed &amp; trained the students for TCS drive. It has covered various recruitment topics like</p> <ul style="list-style-type: none"> <li>• Quantitative Aptitude</li> <li>• Verbal Ability</li> <li>• Logical Reasoning</li> <li>• Communication Skills</li> <li>• Interview skills</li> </ul>

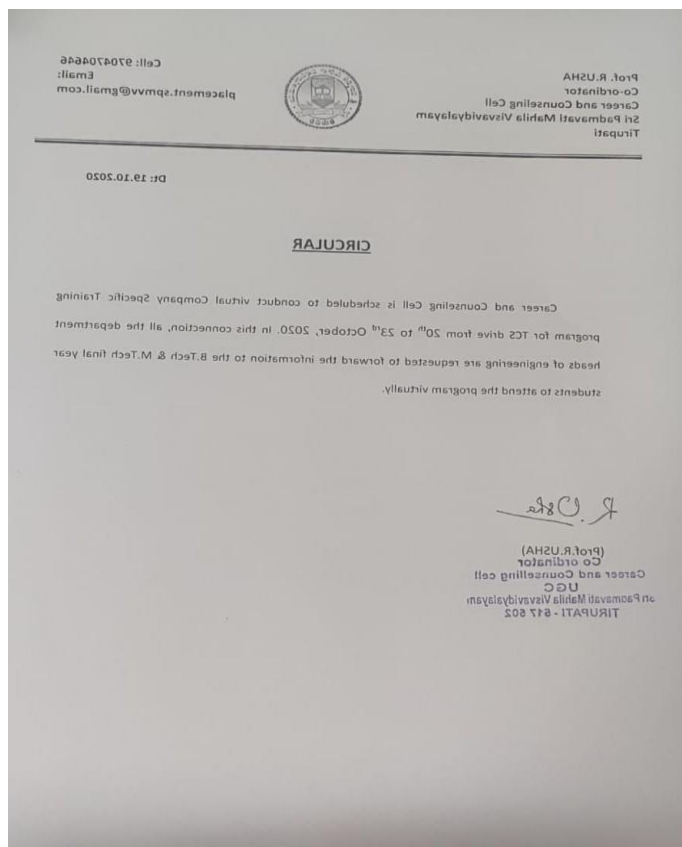

  
**Co ordinator**  
**Career and Counselling cell**  
**UGC**  
**Sri Poomavathi Mahila Viswavidyalayan**  
**TIRUPATI - 517 602**

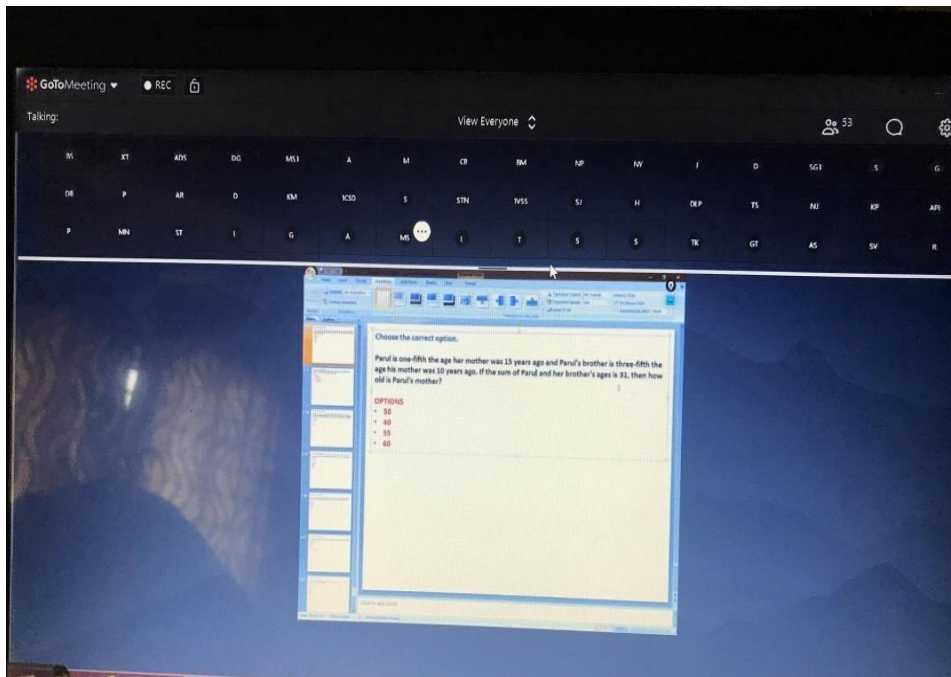
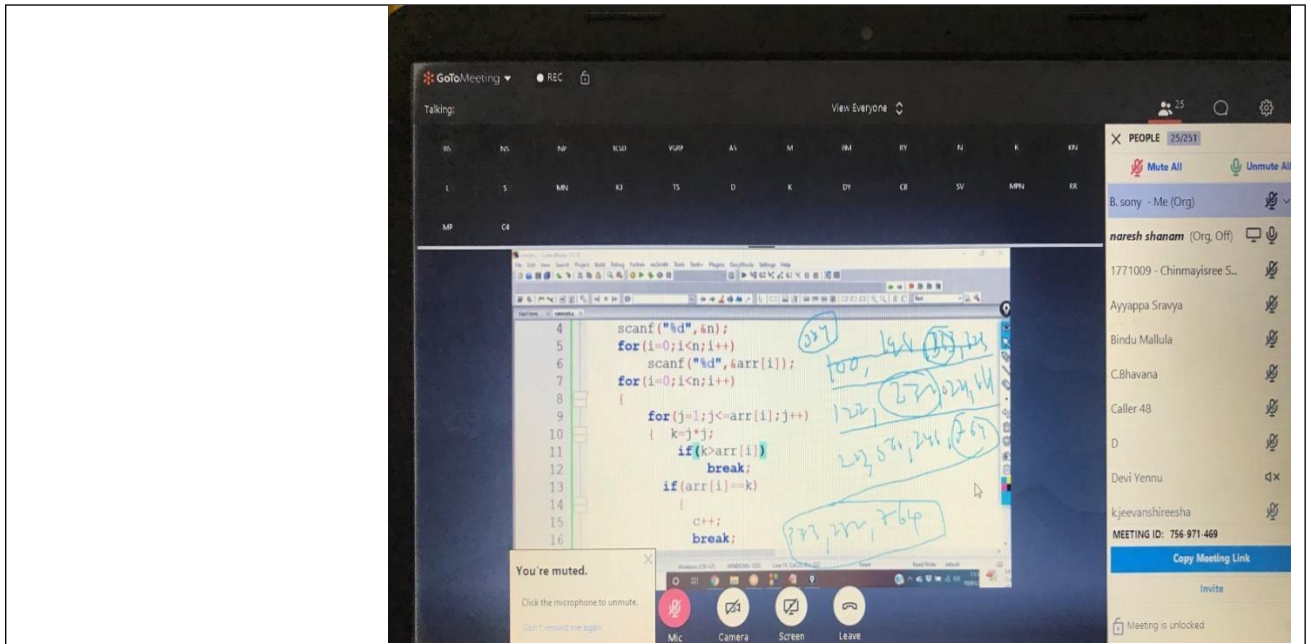

*R. Usha*  
Co ordinator  
Career and Counselling cell  
UGC  
Sri Paomavati Mahila Visvavidyalayam  
TIRUPATI - 617 602

<b>Program No</b>	<b>03</b>
<b>Name of the program</b>	Virtual Interactive Session with the Alumni
<b>Date</b>	12 <sup>th</sup> November, 2020
<b>Venue</b>	Online
<b>Total No of Students</b>	300
<b>Report</b>	<p>Organised one day Virtual Interactive session for 2021 batch students with 2020 Alumni students. This has helped the pre final year students to clear their doubts regarding various company recruitment pattern, and to learn the preparation techniques.</p> <div data-bbox="529 864 1252 1830" data-label="Image"> </div>

  
**Co ordinator**  
**Career and Counselling cell**  
**UGC**  
**Sri Padmavati Mahila Visvavidyalayam**  
**TIRUPATI - 517 502**



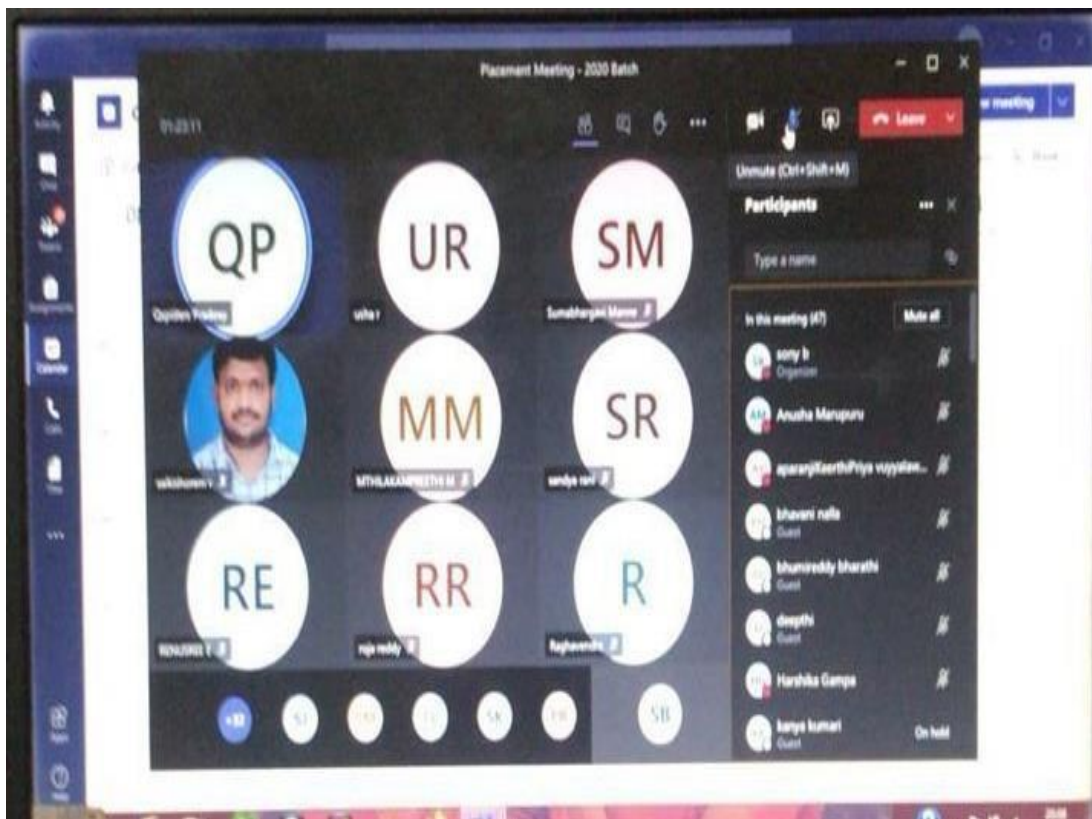
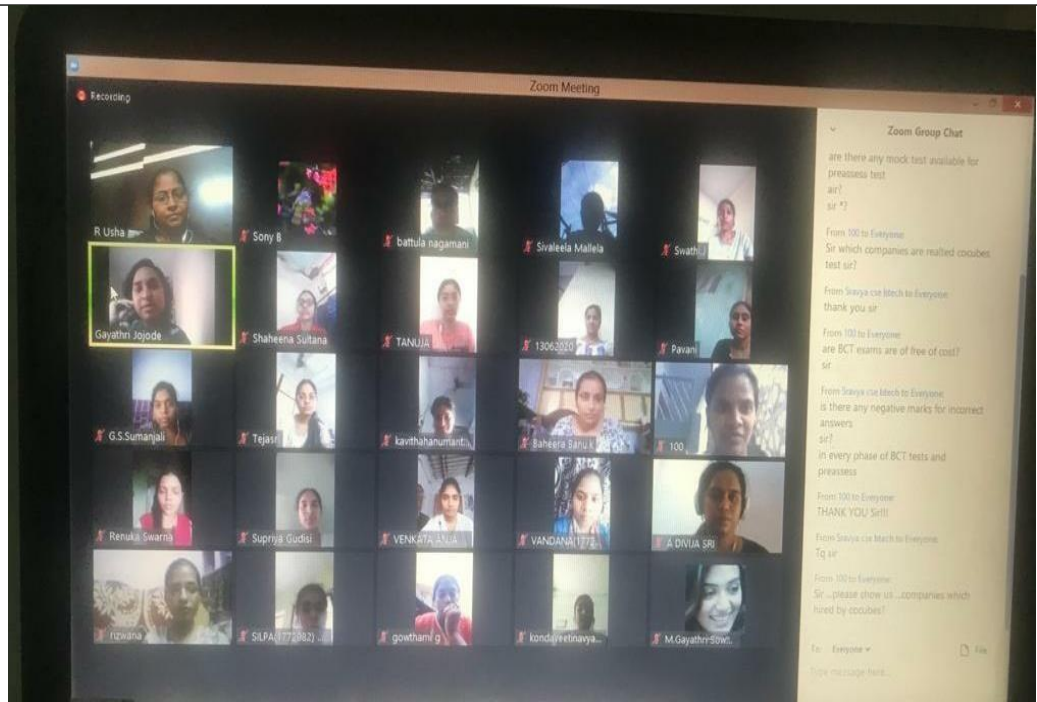

*R. Usha*  
**Co ordinator**  
**Career and Counseling cell**  
**UGC**  
**Sri Padmavati Mahila Visvavidyalayan**  
**TIRUPATI - 517 502**

<b>Program No</b>	<b>04</b>
<b>Name of the program</b>	Explore Skill Test Assessment
<b>Date</b>	25 <sup>th</sup> November, 2020
<b>Venue</b>	Virtual mode
<b>Total No of Students</b>	320
<b>Report</b>	<p>One day virtual assessment test is organised for III year B.Tech, II year M.Tech and III year MCA students by Xplore, Hyderabad to assess the skills of students. This has helped in identifying the strength of students in various modules and to provide required skill training accordingly.</p> <div data-bbox="563 864 1461 1917" data-label="Image"> <p>Prof. R.USHA Co-ordinator Career and Counseling Cell Sri Padmavati Mahila Visvavidyalayam Tirupati</p> <p>Cell: 9704704646 Email: placement.spmvv@gmail.com</p> <p>Dt: 23.01.2021</p> <p><b>CIRCULAR</b></p> <p>Career and Counseling Cell is scheduled to conduct skills assessment test with Xplore pvt ltd to final year B.Tech, M.Tech and MCA students on 25<sup>th</sup> November, 2020. In this connection, I request heads of Departments to forward the information to the B.Tech, M.Tech and MCA final year students to attend the session virtually.</p> <p><i>R. Usha</i></p> <p>(Prof.R.USHA) Co ordinator Career and Counselling cell UGC Sri Paamavati Mahila Visvavidyalayan TIRUPATI - 517 502</p> </div>



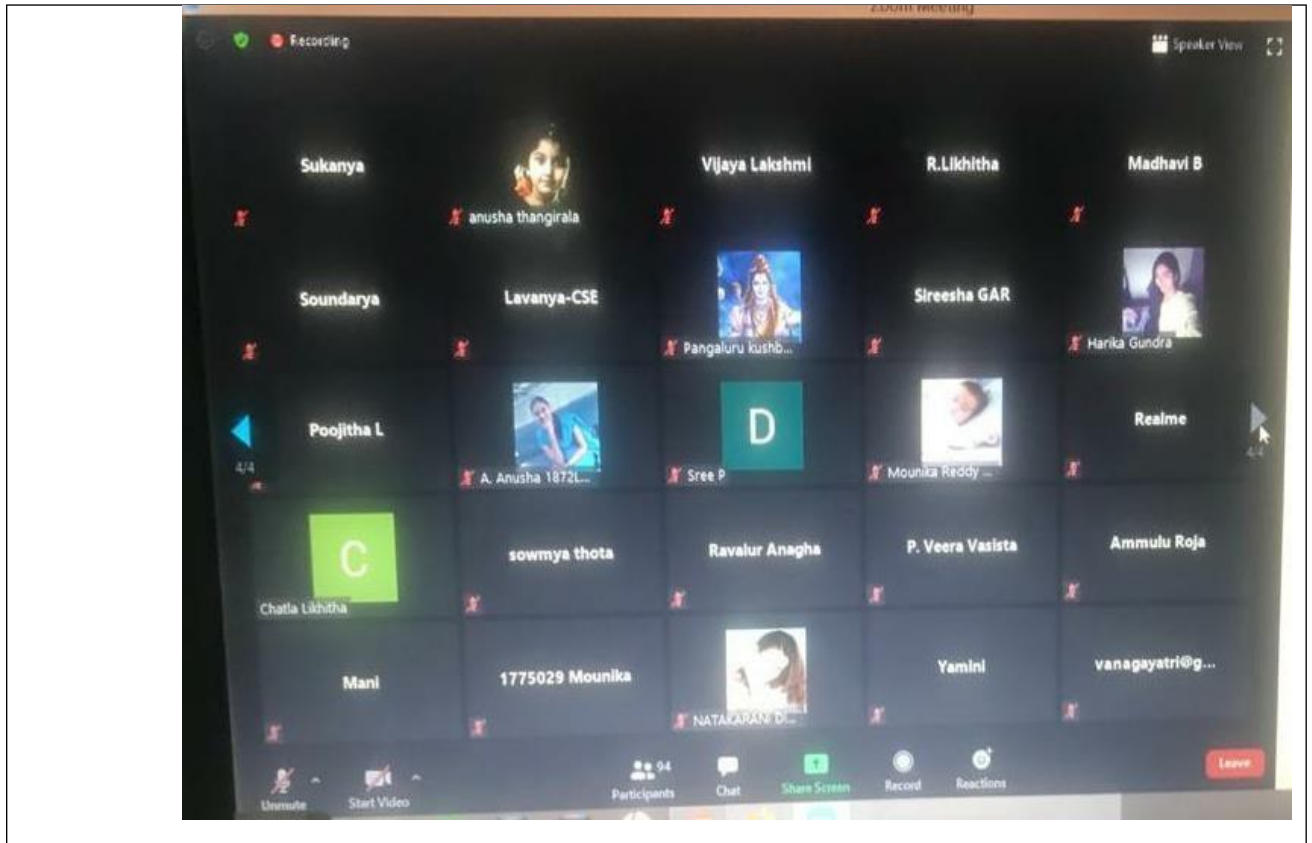

*R. Usha*  
Co ordinator  
Career and Counselling cell  
UGC  
Sri Padmavati Mahila Visvavidyalayan  
TIRUPATI - 517 502

<b>Program No</b>	<b>05</b>
<b>Name of the program</b>	Conducted Wipro Company specific Training Program
<b>Date</b>	08 <sup>th</sup> to 13 <sup>th</sup> January, 2021
<b>Venue</b>	Virtual Mode
<b>Total No of Students</b>	150
<b>Report</b>	<p>Organised six day virtual Wipro company specific training program for 2021 batch students. This has helped the IV Year B.Tech students to learn the preliminary pattern of Wipro recruitment. The training program has covered the below mentioned modules</p> <p><b>Wipro CST Module -Syllabus</b></p> <ul style="list-style-type: none"> <li>• <b>Quantitative Aptitude</b> - LCM HCF, Decimal Fractions, Ratio Proportions, Simplifications, Square roots, Averages, Problems on Ages, Percentages, Profit and Loss, Time and Work, Time and Distance, Problems on Trains, Boats, Simple and Compound Interest, Geometry, Calendar and Clocks, Permutation and Combinations, Data Interpretation</li> <li>• <b>Reasoning-</b> Series Completion, Analogy, Classification, Logical Venn Diagrams, Direction Sense Test, Missing Characters, Assertion and Reason, Statements and Conclusions, Coding and Decoding, Puzzle Test, Blood Relations, Data Sufficiency</li> <li>• <b>Verbal Ability-</b> Synonyms, Antonyms, Spotting Errors, Correct and Incorrect Sentences, Sentence Completion, Sentence Improvement, Sentence Rearrangement, Reading Comprehension Written Communication - Writing Tips, Most frequently asked essay writing questions</li> <li>• <b>Programming Test</b> - Finding Prime number, Palindrome Number, Finding Factorial, Print Fibonacci Series, Finding Leap year, LCM &amp; GCD of two numbers, Removing Duplicates in Array, Bubble Sort</li> </ul>

Prof. R.USHA  
Co-ordinator  
Career and Counseling Cell  
Sri Padmavati Mahila Visvavidyalayam  
Tirupati



Cell: 9704704646  
Email:  
placement.spmvv@gmail.com

Dt: 06.01.2021

### CIRCULAR

Career and Counseling Cell is scheduled to conduct Wipro company specific training program for 6 days (i.e. from 8<sup>th</sup> to 13<sup>th</sup> January, 2020) to B.Tech final year students. In this connection, I request all the department heads of engineering to forward the information to the B.Tech final year students to attend the session virtually.

*R. Usha*

(Prof.R.USHA)  
Co ordinator  
Career and Counselling cell  
UGC  
Sri Padmavati Mahila Visvavidyalayam  
TIRUPATI - 517 502

The screenshot shows a GotoMeeting interface. At the top, it says "Talking: xplore taining" and "View Everyone". There are 66 participants. A chat window on the right shows messages from "K to Everyone" at 9:16 AM, with a count of -1 and 0. The main screen displays a math problem: "Choose the correct option. Find n if  $(2^{228}/2^n) = 512$ ". The options are 219, 218, 237, and "None of the above". Handwritten work shows the calculation:  $2^{228} / 2^n = 512$ ,  $2^{228} = 2^n \times 2^9$ ,  $2^{228} = 2^{n+9}$ ,  $228 = n+9$ ,  $n = 228 - 9$ ,  $n = 219$ . The meeting controls at the bottom include "Unmute yourself", "Screen", and "Leave". The Windows taskbar at the bottom shows the time as 9:35 AM on 1/9/2021.

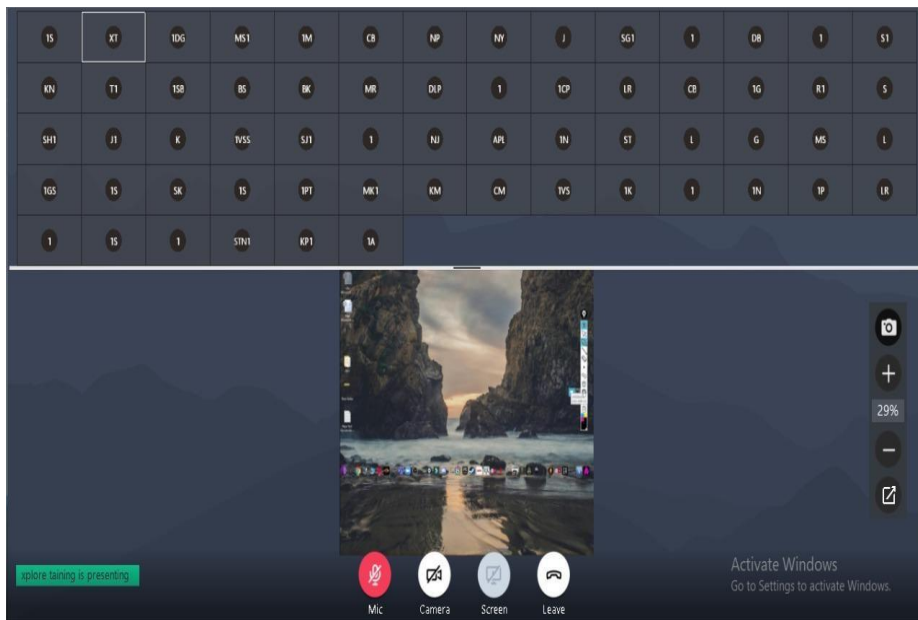
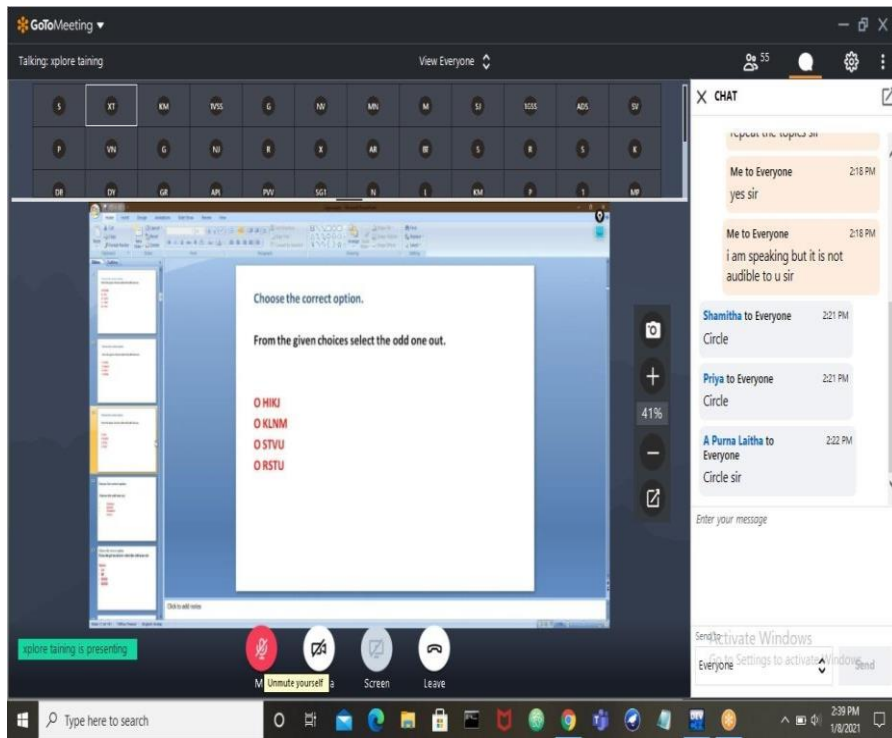

*R. Usha*  
 Co ordinator  
 Career and Counselling cell  
 UGC  
 Sri Padmavati Mahila Visvavidyalayam  
 TIRUPATI - 617 602

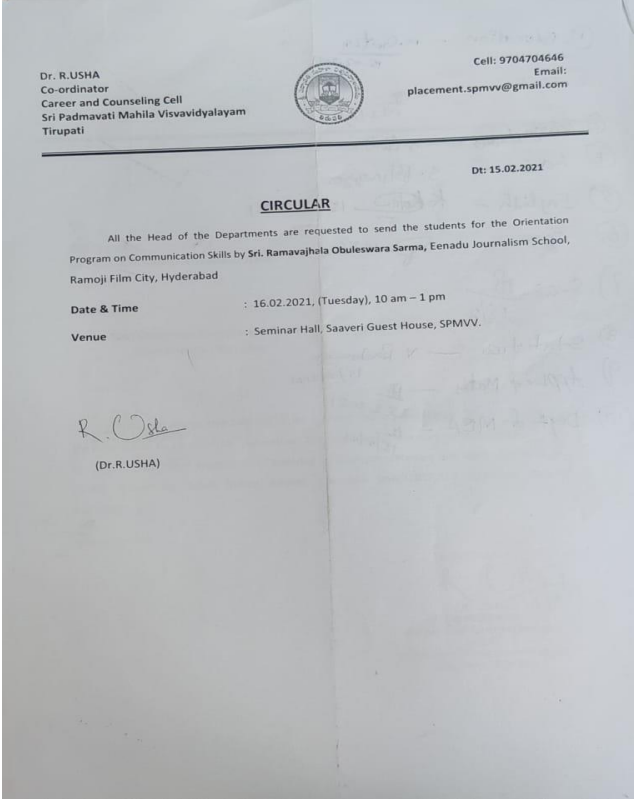
<b>Program No</b>	<b>06</b>
<b>Name of the program</b>	Orientation program on Communication Skills
<b>Date</b>	16 <sup>th</sup> February 2021
<b>Venue</b>	Saaveri Seminar Hall, SPMVV
<b>Total No of Students</b>	376
<b>Report</b>	<p>Organized Orientation program on Communication Skills by Sri R.ObuleswaraSarma to B.Tech and Social sciences students. Good communication skills are essential to allow others and yourself to understand information more accurately and quickly. In contrast, poor communication skills lead to frequent misunderstandings and frustration.</p> <p>This has helped the B.Tech and Social sciences students to understand the importance of communication skills.</p> 

Circular

3 messages

Mon, Feb 15, 2021 at 3:08 PM

placement.spmvv <placement.spmvv@gmail.com>
Reply-To: placement.spmvv@gmail.com
To: gen biotech <genbiotechspmvv@gmail.com>, Home Science <hoscienspmvv@gmail.com>, Music <mamusicspmvv@gmail.com>, Nursing SPMVV <mncspmvv@gmail.com>, Pharmacy <spmvvpharmatechnology@gmail.com>, Physical Education <mpeidspmvv@gmail.com>, Physics <spvphysspmvv@gmail.com>, Prof. C. Eswara Reddy <director.spmvv@gmail.com>, Sericulture <serispmvv@gmail.com>, social work <swspmvv@gmail.com>, <spmvv.mba> <spmvv.mba@gmail.com>, Mca Spmvv <mca.spmvv.office@gmail.com>, Microbiology <microbiospmvv@gmail.com>, Statistics <mncstatisticsspmvv@gmail.com>, mathspmvv56@gmail.com, Law Department <spmvvlawdept@gmail.com>, mci spmvv <mcispmvv@gmail.com>, Education Department <education.spmvv@gmail.com>, English <maenglishspmvv@gmail.com>, Telugu <mateluguspmvv@gmail.com>, Women's Studies <wsspmvv@gmail.com>

Dear All

CIRCULAR

All the Head of the Departments are requested to send the students for the Orientation Program on Communication Skills by Sri. Ramavajhala Obuleswara Sarma, Eenadu Journalism School, Ramoji Film City, Hyderabad

Date & Time : 16.02.2021, (Wednesday), 10 am – 1 pm

Venue : Seminar Hall, Saaveri Guest House, SPMVV.

Regards
Prof. R. Usha
Placement Officer
Sri Padnavati Mahila Viswavidyalayam
Tirupati (AP)
Mobile: 9704704646
Office: 0877-2284554

Mon, Feb 15, 2021 at 4:08 PM

placement.spmvv <placement.spmvv@gmail.com>
Reply-To: placement.spmvv@gmail.com
To: gen biotech <genbiotechspmvv@gmail.com>, Home Science <hoscienspmvv@gmail.com>, Music <mamusicspmvv@gmail.com>, Nursing SPMVV <mncspmvv@gmail.com>, Pharmacy <spmvvpharmatechnology@gmail.com>, Physical Education <mpeidspmvv@gmail.com>, Physics <spvphysspmvv@gmail.com>, Prof. C. Eswara Reddy <director.spmvv@gmail.com>, Sericulture <serispmvv@gmail.com>, social work <swspmvv@gmail.com>, <spmvv.mba> <spmvv.mba@gmail.com>, Mca Spmvv <mca.spmvv.office@gmail.com>, Microbiology <microbiospmvv@gmail.com>, Statistics <mncstatisticsspmvv@gmail.com>, mathspmvv56@gmail.com, Law Department <spmvvlawdept@gmail.com>, mci spmvv <mcispmvv@gmail.com>, Education Department <education.spmvv@gmail.com>, English <maenglishspmvv@gmail.com>, Telugu <mateluguspmvv@gmail.com>, Women's Studies <wsspmvv@gmail.com>

Sry Ma'am wrongly entered as wednesday it's tuesday tomorrow.

Date & Time : 16.02.2021, (Tuesday), 10 am – 1 pm

Regards
Prof. R. Usha
Placement Officer
Sri Padnavati Mahila Viswavidyalayam
Tirupati (AP)
Mobile: 9704704646
Office: 0877-2284554

[Quoted text hidden]

Mon, Feb 15, 2021 at 5:14 PM

placement.spmvv <placement.spmvv@gmail.com>
Reply-To: placement.spmvv@gmail.com
To: gen biotech <genbiotechspmvv@gmail.com>, Home Science <hoscienspmvv@gmail.com>, Nursing SPMVV <mncspmvv@gmail.com>, Pharmacy <spmvvpharmatechnology@gmail.com>, Physics <spvphysspmvv@gmail.com>, Microbiology <microbiospmvv@gmail.com>, serispmvv@gmail.com

Dear madam

This is to inform you that, the tomorrow's orientation program on communication skills have been cancelled for science students and will intimate the schedule shortly.

With regards
Dr. R. Usha
Placement officer
Spmvv
Tirupati
[Quoted text hidden]







*R. Usha*  
Co ordinator  
Career and Counselling cell  
UGC  
Sri Padmavati Mahila Viswavidyalayan  
TIRUPATI - 617 602

<b>Program No</b>	<b>07</b>
<b>Name of the program</b>	Online Linux and Shell Scripting Basics
<b>Date</b>	22 <sup>nd</sup> March 2021 to 31st March 2021
<b>Venue</b>	SoET, SPMVV
<b>Total No of Students</b>	135
<b>Report</b>	<p>Organized online training program on Linux and shell scripting basics Sponsored by APSSDC. Using a shell script is most useful for repetitive tasks that may be time consuming to execute by typing one line at a time. A few examples of applications shell scripts can be used for include: Automating the code compiling process. Running a program or creating a program environment.</p> <p>A total number of 135 students from the school of Engineering and technology, SPMVV have actively participated in this 36 horus training workshop and certified. The basics were taught commonly for all the students on online mode with the live practice classes after completing basics a test has been conducted to qualify for the next level in this way it took everyday training and finally 135 students got the completion certificate from APSSDC.</p>

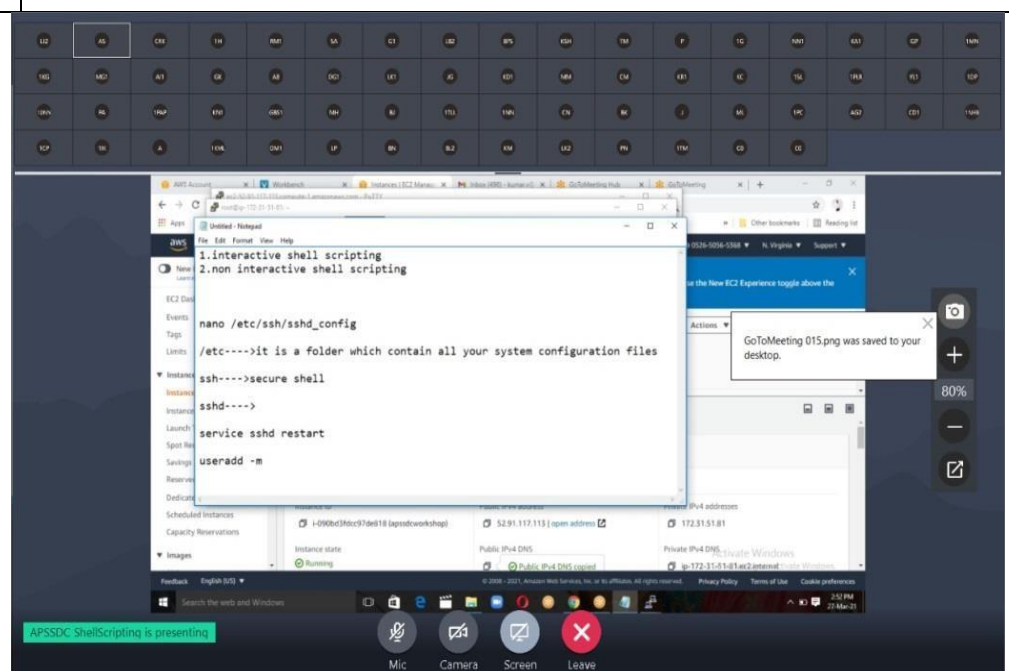

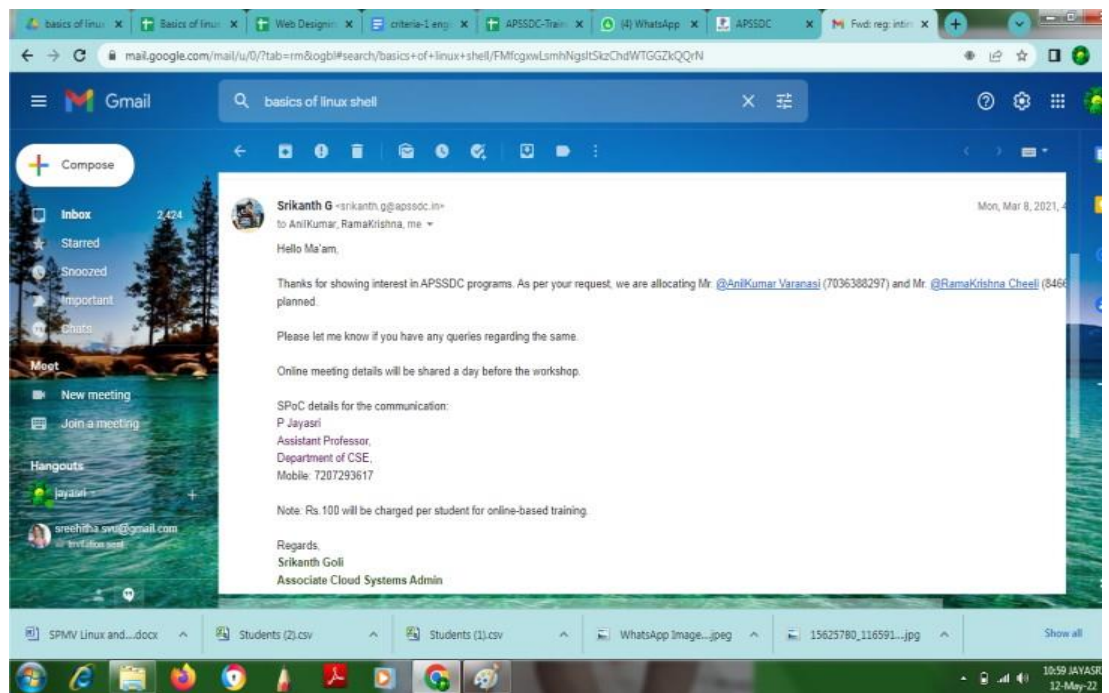
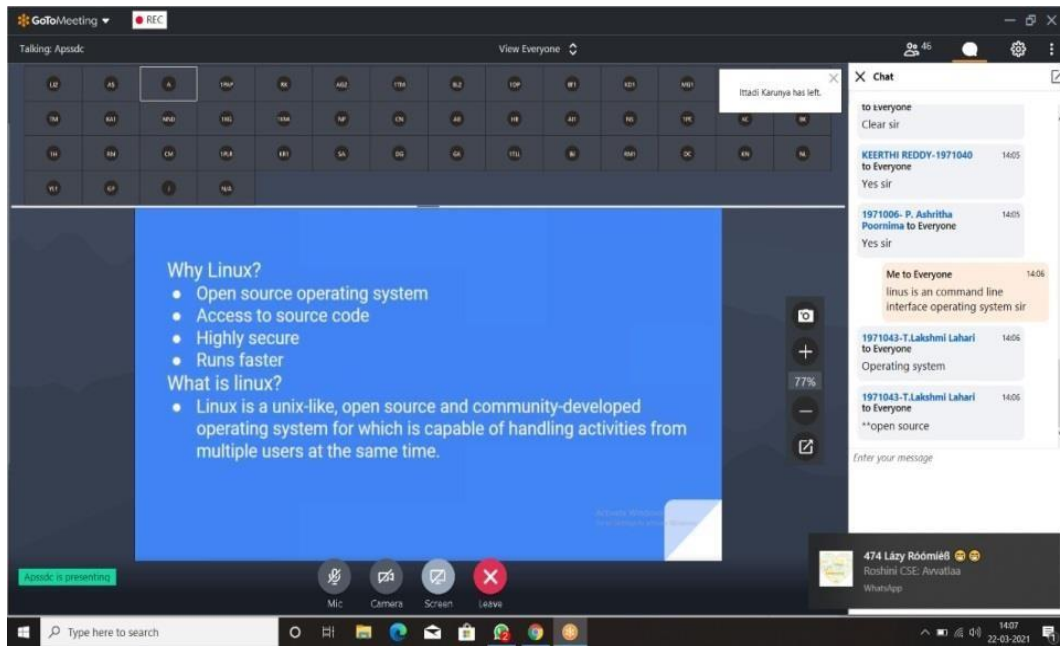

*R. Usha*  
**Co ordinator**  
**Career and Counselling cell**  
**UGC**  
**Sri Paavathi Mahila Visvavidyalayan**  
**TIRUPATI - 617 602**

<b>Program No</b>	<b>08</b>
<b>Name of the program</b>	Game Designing Using Build box
<b>Date</b>	22 <sup>nd</sup> March 2021 to 31st March 2021
<b>Venue</b>	SoET,SPMVV
<b>Total No of Students</b>	127
<b>Report</b>	<p>A Training Program on Game Designing Using Build box, through APSSDC. A total number of 127 students from the school of Engineering and technology, SPMVV have actively participated in this 36 horus training workshop and certified.</p> <p>This workshop is carry forwarded by various steps in which the students has been tested by experts from APSSDC. The basics are taught commonly for all the students on online mode with the live practice classes after completing basics a test has been conducted to qualify for the next level in this way it took everyday training and finally 127 students got the completion certificate from APSSDC.</p>

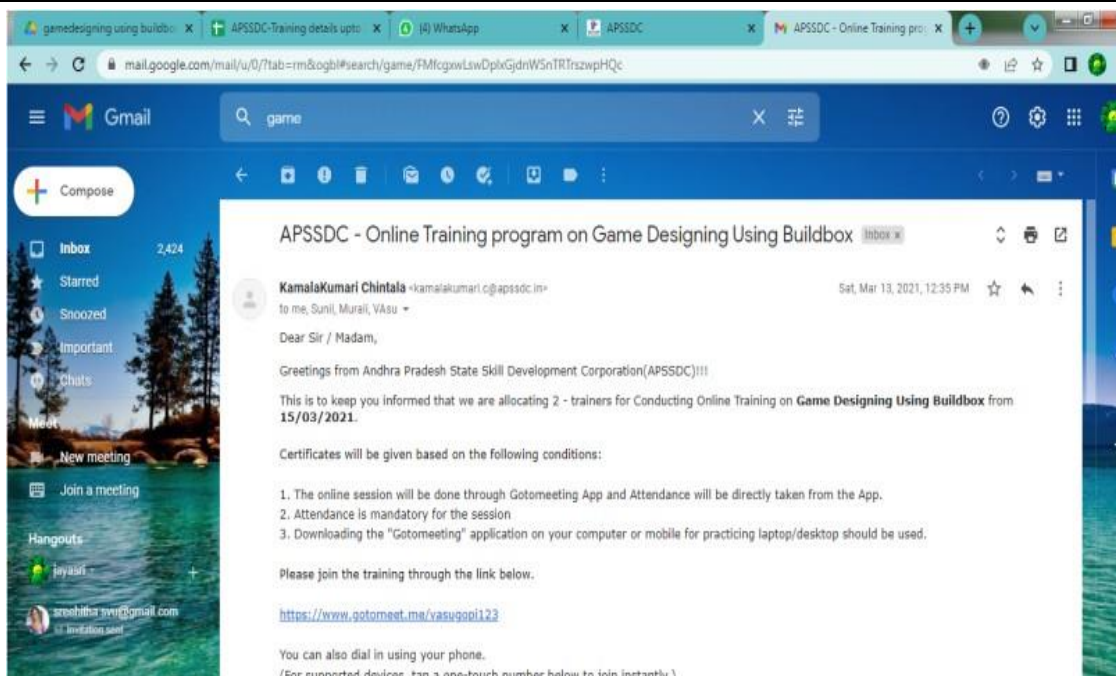

*R. Usha*  
**Co ordinator**  
**Career and Counselling cell**  
**UGC**  
**Sri Paomavati Mahila Visvavidyalayan**  
**TIRUPATI - 517 502**

<b>Program No</b>	<b>09</b>																																				
<b>Name of the program</b>	APSSDC Summer Training Program																																				
<b>Date</b>	17 <sup>th</sup> May to 5 <sup>th</sup> June 2021																																				
<b>Venue</b>	SoET,SPMVV																																				
<b>Total No of Students</b>	II, III and IV Year Students of School of Engineering and Technology																																				
<b>Report</b>	<p>Three Weeks training programs is organized, Sponsored by APSSDC. The training program has covered 16 technologies.</p> <p>A total number all branch students from CSE,ECE,EEE,Mech 2<sup>nd</sup> and 3<sup>rd</sup> years students of the school of Engineering and technology, SPMVV have actively participated in this 3 Weeks training workshop and certified.</p> <p>This workshop has been organized by SoET with the APSSDC. From 17<sup>th</sup> may to june 5<sup>th</sup> 2021Parallaly 16 workshops has been conducted by various resource persons from APSSDC on different technologies on tentative dates among all 16 workshops some are of 1 week duration and some are of 2 weeks duration and some are of 3 week duration the tentative dates are</p> <table border="0"> <tr> <td>1.Amazon Web Service</td> <td>17-05-2021</td> <td>03-06-2021</td> </tr> <tr> <td>2.Android application development</td> <td>17-05-2021</td> <td>05-06-2021</td> </tr> <tr> <td>3.basics linux and shell scripting</td> <td>17-05-2021</td> <td>22-05-2021</td> </tr> <tr> <td>4.Basics of Cyber Security</td> <td>17-05-2021</td> <td>22-05-2021</td> </tr> <tr> <td>5.Data analysis using python</td> <td>17-05-2021</td> <td>05-06-2021</td> </tr> <tr> <td>6.Fundamentals Of Drone</td> <td>24-05-2021</td> <td>29-05-2021</td> </tr> <tr> <td>7.Internet of Things</td> <td>17-05-2021</td> <td>05-06-2021</td> </tr> <tr> <td>8.machine learning using python</td> <td>17-05-2021</td> <td>05-06-2021</td> </tr> <tr> <td>9.mechanical components drafting by autocad</td> <td>17.05.2021</td> <td>02.06.2021</td> </tr> <tr> <td>10. Source code management using Github</td> <td>17-05-2021</td> <td>22-05-2021</td> </tr> <tr> <td>11.Python programming</td> <td>17-05-2021</td> <td>03-06-2021</td> </tr> <tr> <td>12.Web designing using React JS</td> <td>17-05-2021</td> <td>05-06-2021</td> </tr> </table>	1.Amazon Web Service	17-05-2021	03-06-2021	2.Android application development	17-05-2021	05-06-2021	3.basics linux and shell scripting	17-05-2021	22-05-2021	4.Basics of Cyber Security	17-05-2021	22-05-2021	5.Data analysis using python	17-05-2021	05-06-2021	6.Fundamentals Of Drone	24-05-2021	29-05-2021	7.Internet of Things	17-05-2021	05-06-2021	8.machine learning using python	17-05-2021	05-06-2021	9.mechanical components drafting by autocad	17.05.2021	02.06.2021	10. Source code management using Github	17-05-2021	22-05-2021	11.Python programming	17-05-2021	03-06-2021	12.Web designing using React JS	17-05-2021	05-06-2021
1.Amazon Web Service	17-05-2021	03-06-2021																																			
2.Android application development	17-05-2021	05-06-2021																																			
3.basics linux and shell scripting	17-05-2021	22-05-2021																																			
4.Basics of Cyber Security	17-05-2021	22-05-2021																																			
5.Data analysis using python	17-05-2021	05-06-2021																																			
6.Fundamentals Of Drone	24-05-2021	29-05-2021																																			
7.Internet of Things	17-05-2021	05-06-2021																																			
8.machine learning using python	17-05-2021	05-06-2021																																			
9.mechanical components drafting by autocad	17.05.2021	02.06.2021																																			
10. Source code management using Github	17-05-2021	22-05-2021																																			
11.Python programming	17-05-2021	03-06-2021																																			
12.Web designing using React JS	17-05-2021	05-06-2021																																			



13. Web development using django	17-05-2021	05-06-2021
14. PRODUCT DESIGN AND DRAFTING BY CATIA	17-05-2021	02-05-2021
15. industrial automation with PLC	17-05-2021	05-06-2021
16. embedded systems	17-05-2021	05-06-2021

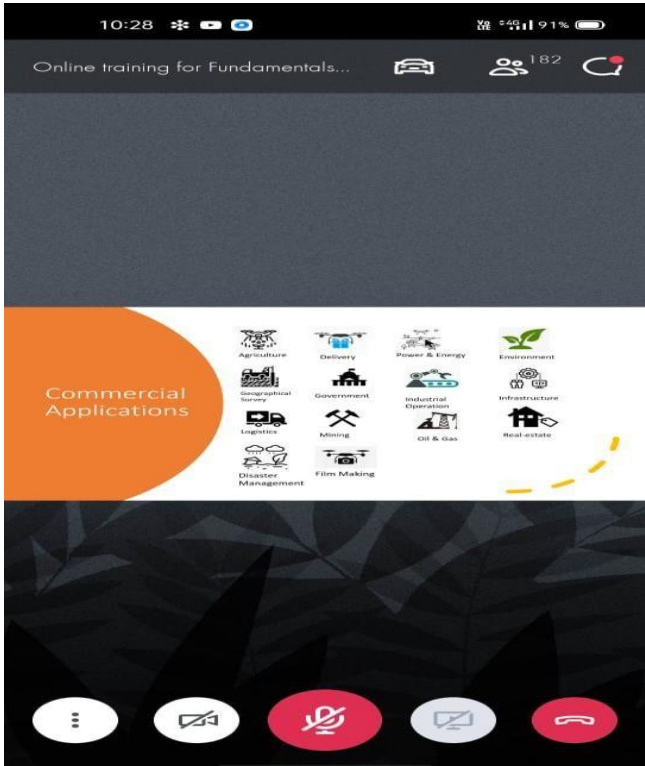
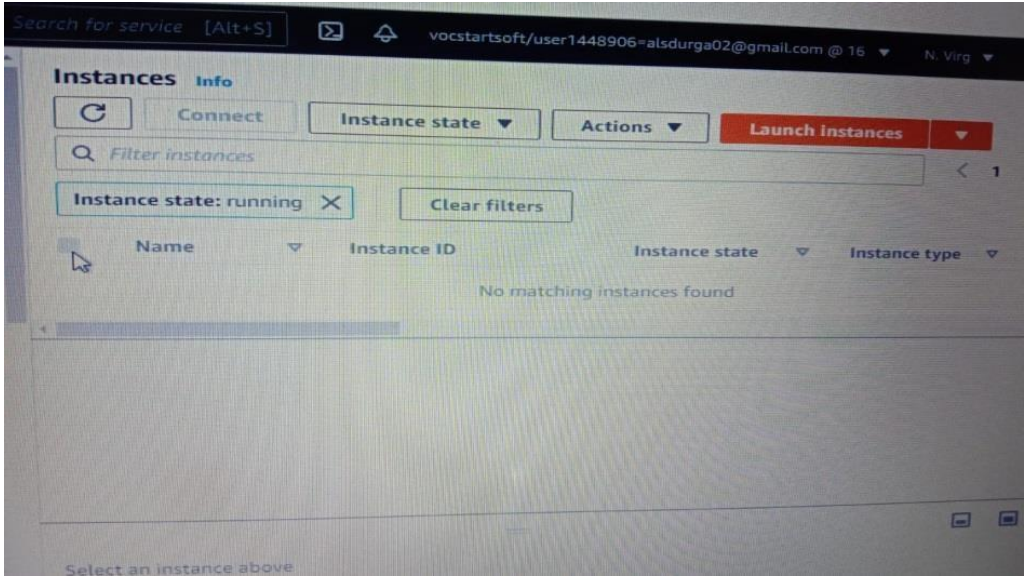



GoToMeeting | REC | Talking: Android workshop | View Everyone

```

65 *-----Service-----*
66 *Content Provider -> photos, audio, video, contacts, etc*
67 *for ex: content--> photos, audio, video, contacts, etc*
68 *case: 1:*
69 *contact--> sai - apssdc 487845*
70 *contacts--> whatsapp, hike, fb, etc*
71 *sd card sai 487845*
72 *=====Service=====*
73 *API-service-->*
74 *Application Programming Interface*
75 *Rest API-->*
76 *Repräsentational State Transfer API*
77 *HTTP-*
78 *JSON->*
79 *XML->*
80
81
82

```

Chat:

- s sir
- Me to Everyone 16:58  
yes sir
- Me to Everyone 16:59  
application program interface
- Y14AE402-SAIKUMAR.ADDURI-BAPATLA ENGINEERING COLLEGE to Everyone  
APPLICATION PROGRAMMING INTERFACE
- (18H71A0457)(Chandrika) (Mic College) to Everyone  
Application program interface
- Y14AE402-SAIKUMAR.ADDURI-BAPATLA ENGINEERING COLLEGE to Everyone  
EXAMPLE

GoToMeeting | REC | Talking: Android workshop | View Everyone

```

73 *Repräsentational State Transfer API*
74 *HTTP-*
75 *JSON-> java script object notation*
76 *XML->*
77
78
79
80 *we are interconnection with web API Services*
81
82 *--> without API Services*
83 *engineering college -> AU, BEC,*
84 *AU -> Engineering-dept -> cse -> 2020*
85 *sections A(60), B, C, D, etc*
86 *240 -> 10mb*
87 *BEC -> Engineering-dept -> cse -> 2020*
88 *sections A, B, C, D, etc*
89
90
91
92
93

```

Chat:

- Y14AE402-SAIKUMAR.ADDURI-BAPATLA ENGINEERING COLLEGE to Everyone  
1973
- 319506402124-Vinukonda Sarayu-Andhra University College Of Engineering to Everyone  
once repeat your question sir
- 319506402124-Vinukonda Sarayu-Andhra University College Of Engineering to Everyone  
yes sir
- 319506402124-Vinukonda Sarayu-Andhra University College Of Engineering to Everyone  
sir\*
- Y14AE402-SAIKUMAR.ADDURI-BAPATLA ENGINEERING COLLEGE to Everyone  
yes

*R. Usha*  
**Co ordinator**  
**Career and Counselling cell**  
**UGC**  
**Sri Pramavati Mahila Visvavidyalayan**  
**TIRUPATI - 517 502**

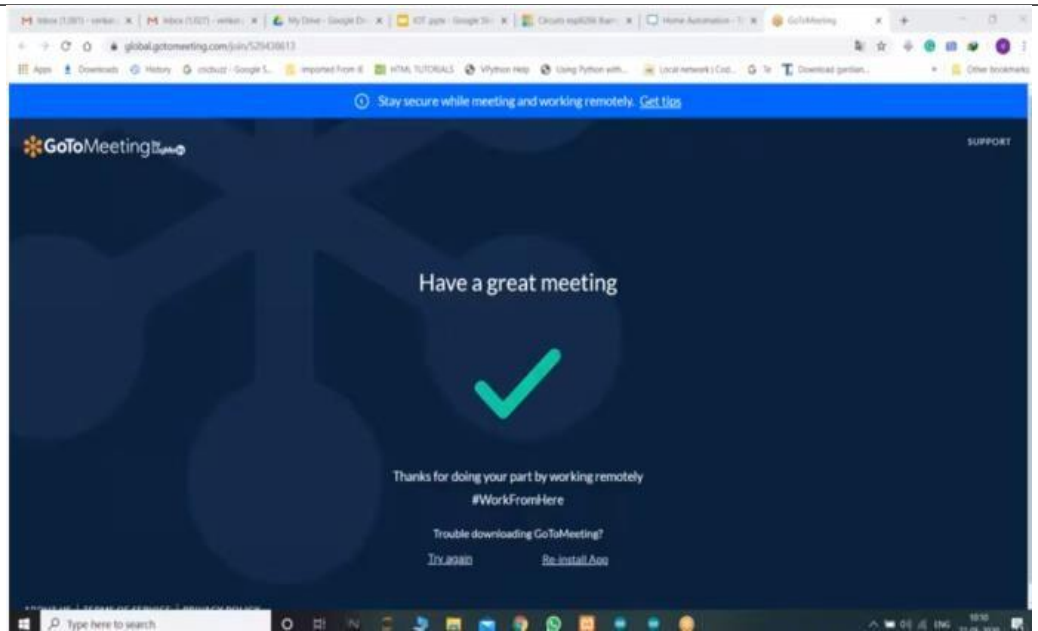

*R. Usha*  
Co ordinator  
Career and Counselling cell  
UGC  
Sri Padmavati Mahila Visvavidyalayam  
TIRUPATI - 517 502

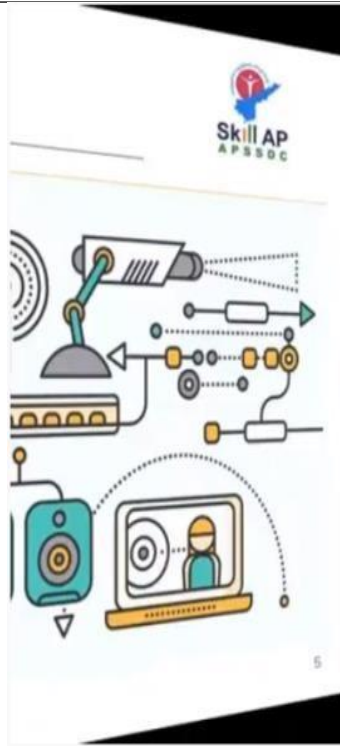

**Data:**

From the beginning to 2005 of Human Era, Humans created 130 Exabytes of data

DB	BD	VK	BK	SB	KL	AR	HK	SA	AR	CB	MK	BB	AA	AC	P	RA	SK	S	MV	CP	NN	DB	AS	JG	KK	
G	KU	MK	B	S	PA	AK	GJ	AA	J	AT	DK	BS	RK	NA	TM	RY	R	J	PR	A	DM	PR	JS	IA	MM	KG
										AJ	G	P	MK	PH	RR	R										

Recording...

Mic Camera Screen Leave

*R. Usha*  
 Co ordinator  
 Career and Counselling cell  
 UGC  
 Sri Padavathi Mahila Visvavidyalayam  
 TIRUPATI - 517 502

File Edit View History Bookmarks Tools Help

What's new with... WhatsApp (339) YouTube Documents/Workshops content/ML Reference/ML Reference/Machine-Learning-Online- 07-08-2021 - Jup... 06-08-2021 - Jup... UCI Machine Learnin... k means cluster... K-Means Cluster...

localhost:8888/notebooks/Documents/Workshops content/ML Reference/ML Reference/Machine-Learning-Online- 170%

jupyter 07-08-2021 (autosaved) Logout

File Edit View Insert Cell Kernel Widgets Help Not Trusted Python 3

In [4]:

```
1 df1.columns = cancer['feature_names']
2 df1.head()
```

In [5]:

```
1 df1['Target'] = cancer['target']
2 df1.head()
```

Out[5]:

mean cell nucleus	mean compactness	mean concavity	mean concave points	mean symmetry	mean fractal dimension	...	worst texture	worst perimeter	worst area	w smoothr
340	0.27760	0.3001	0.14710	0.2419	0.07871	...	17.33	184.60	2019.0	0.1
474	0.07864	0.0869	0.07017	0.1812	0.05667	...	23.41	158.80	1956.0	0.1

Type here to search Desktop 29°C 10:54 09-04-2022

4G 17:57 40% 4G

Anil Kumar Teegala (APSSDC) is talking

Git as Version Control

Git Terminology

- Repository** - Your project directory
- Branch** - A version of your repository
- Commit** - A checkpoint on a branch
- Master Branch** - The main branch of your software

SKILAP APSSDC

R. Usha  
 Co ordinator  
 Career and Counselling cell  
 UGC  
 Sri Padmavati Mahila Visvavidyalayan  
 TIRUPATI - 517 502



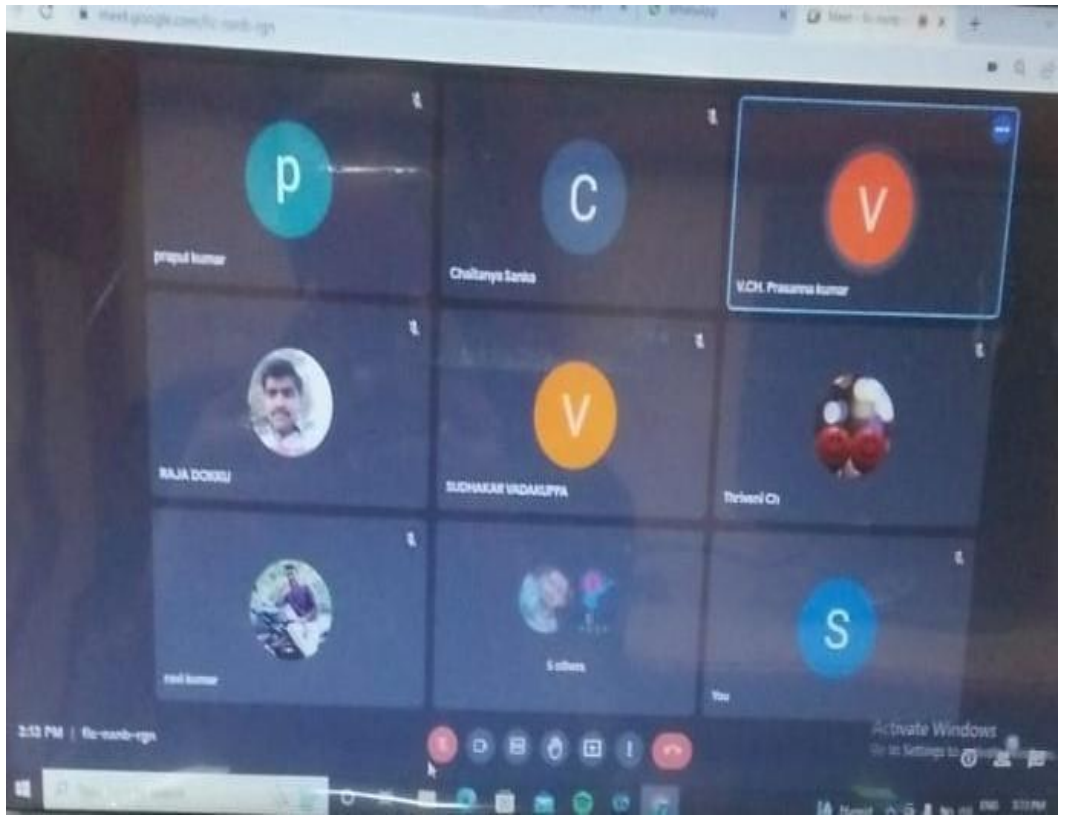
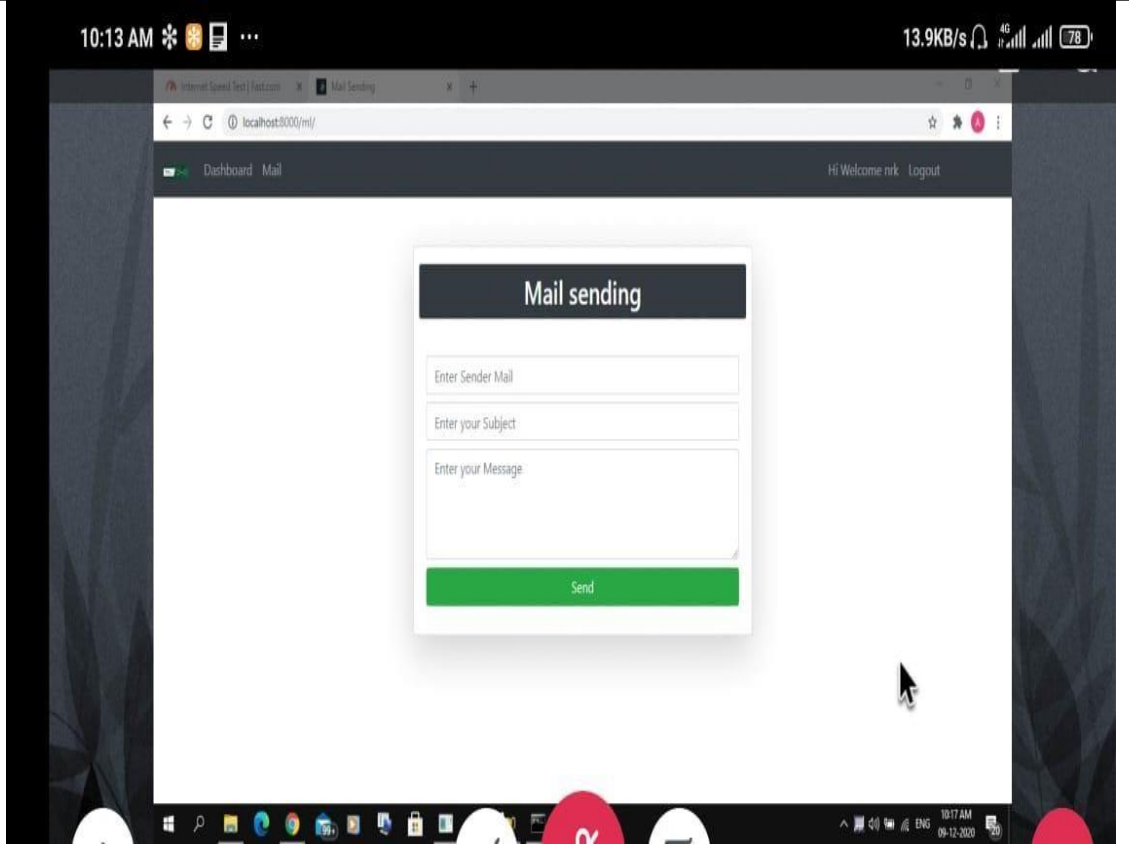

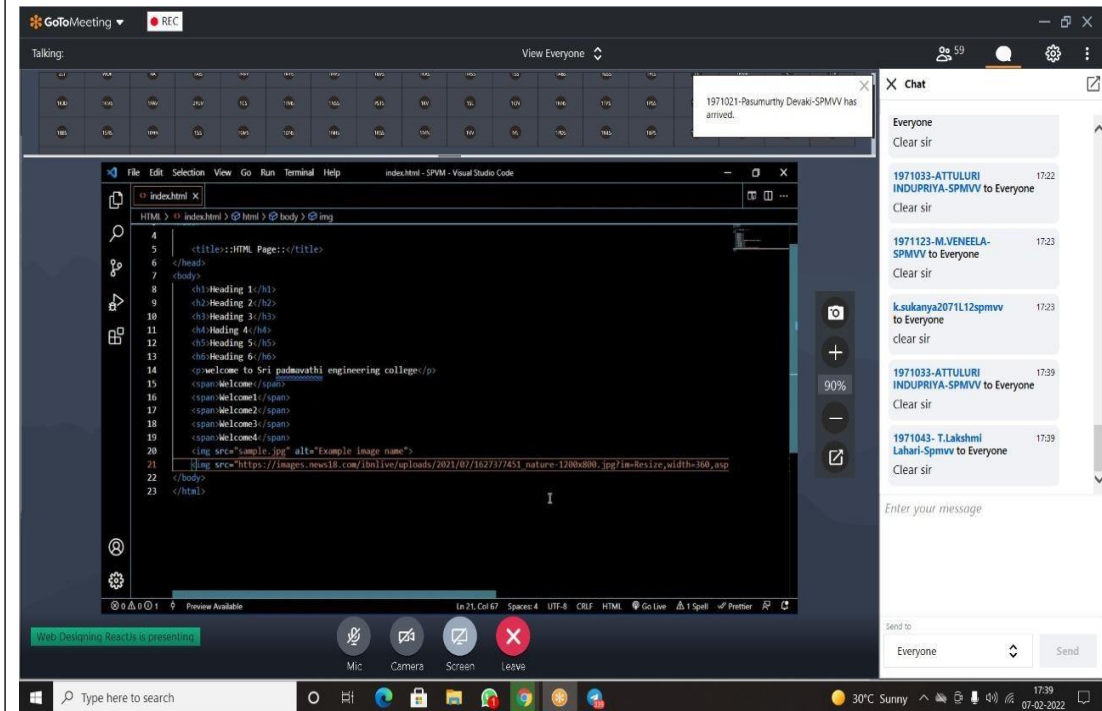
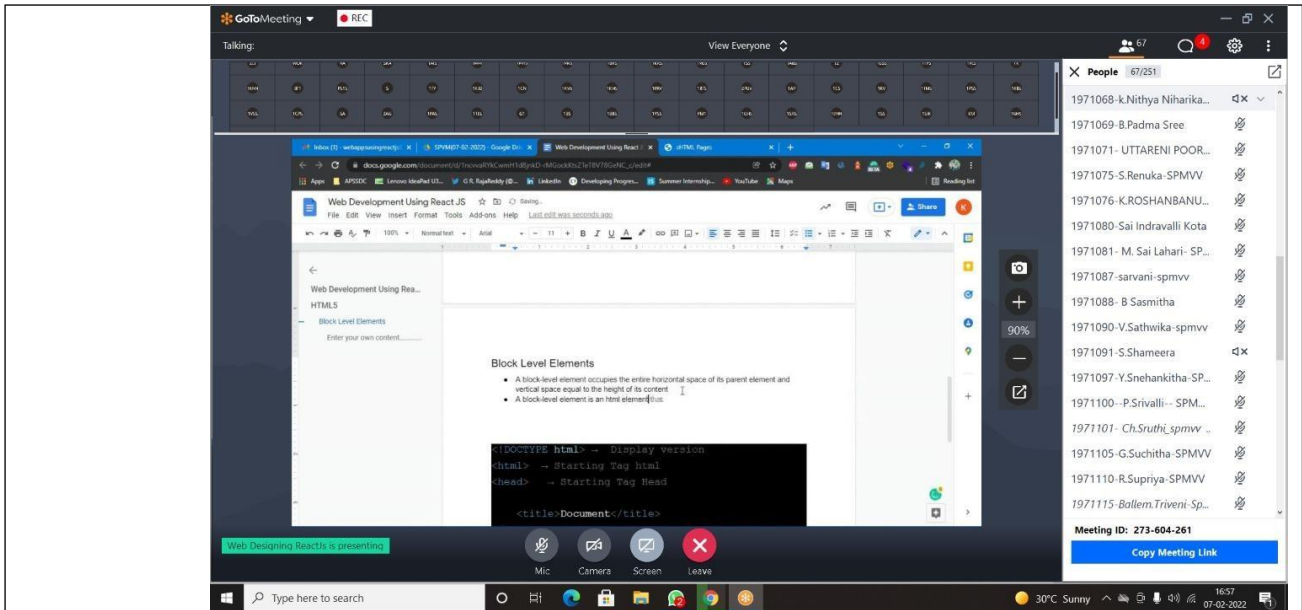

*R. Usha*  
 Co ordinator  
 Career and Counselling cell  
 UGC  
 Sri Padavathi Mahila Visvavidyalayan  
 TIRUPATI - 617 602



web designing using | Web development us... | critena-1 engineering - | APSSDC-Training deta... | (4) WhatsApp | APSSDC | engineering.apssdc.in

**Andhra Pradesh State Skill Development Corporation (APSSDC)**  
 (Department of Skill Development & Training, Govt. of Andhra Pradesh)

Home Forms Reports Logout

Program wise report

Program >> Web Development Using Django Online 2021-22, Course >> Python

S.No.	Registration Id	Name	Email	Phone	Category	Payment	Edit	Action
1	1871008	Tere Bahargavi	bhargaviteree@gmail.com	7993603402	SC	SUCCESS		
2	1871009	Naru Bhavana	narubhavana2001@gmail.com	7386909966	BC-B	SUCCESS		
3	1871016	Nagalla Charvi Charitha	nagallacharvicharitha@gmail.com	9573603386	BC-D	SUCCESS		
4	1871018	M D Deevavani	rdamrthardevavani@gmail.com	9290060644	BC-B	SUCCESS		

Copyright © APSSDC

Students (2).csv Students (1).csv WhatsApp image...jpeg 15625780\_116591...jpg 15676043\_116589...jpg Show all

10:22 AM YASR 12-May-22

GoToMeeting REC

Talking: View Everyone

Chat

yes sir

11HN1A0220-NUTAN-ADARSH COLLEGE OF ENGINEERING to Everyone 16:57

5 sir

Me to Everyone 16:58

yes sir

Me to Everyone 16:59

application program interface

Y14AE5402-SAIKUMAR.ADDURI-BAPATLA ENGINEERING COLLEGE to Everyone 16:59

APPLICATION PROGEAMING INTERFACE

(18H71A0467)(Chandrika) (Mc College) to Everyone 17:00

Application program interface

Send to: Everyone Send

```

62 ----->broadcast receivers -->use that signal..
63
64 4.Content Provider:provding content between two apps
65 for ex:content-->photos,audio,video ,contacts..etc
66 case:1
67 contact-->sai -apssdc 487845
68 contct-->whatsapp,hike,fb,..etc
69 sdc sai 487845
70
71 =====Service=====
72 API-service-->
73 Application Programming Interface
74 Rest API-->
75
76
77
78
79
  
```

Windows taskbar: Type here to search, 17:00, 31-05-2021

*R. Usha*  
 Co ordinator  
 Career and Counselling cell  
 UGC  
 Sri Padavathi Mahila Viswavidyalayam  
 TIRUPATI - 517 502

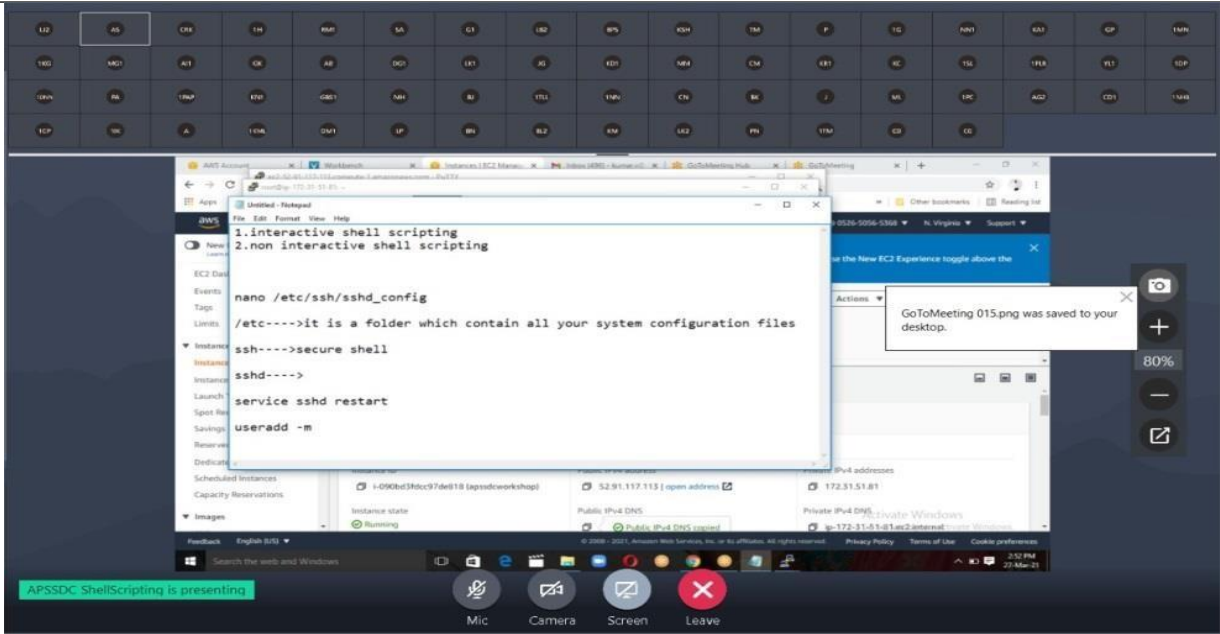

basics of cyber se x android internshp x Web developmen x criteria-1 engine x APSSDC-Training x (4) WhatsApp x APSSDC x

Not secure | engineering.apssdc.in

**Andhra Pradesh State Skill Development Corporation (APSSDC)**  
(Department of Skill Development & Training, Govt. of Andhra Pradesh)

Home Forms Reports Logout

Program wise report

Program >> Basics Of Cybersecurity 2021-22 - Online , Course >> Basics Of Cyber Security

S.No.	Registration Id	Name	Email	Phone	Category	Payment	Edit	Action
1	1672018	Tangi Deepthi	tangideepthi21@gmail.com	7330946425	BC-D	-		
2	1771021	Vemulakonda Gowri Ratna Priya	vgowrirathnapriya@gmail.com	9059733347	BC-B	-		
3	1772115	Pilli Venkata Sanjana	venkatasanjanapilli@gmail.com	9000612578	OBC	-		
4	1871005	Neerasa Anusha	neerasaanusha@gmail.com	7286015568	BC-D	SUCCESS		

Copyright © APSSDC

Students (2).csv Students (1).csv WhatsApp Image...jpeg 15625780\_116591...jpg 15676043\_116589...jpg Show all

10:30 JAVASR 12-May-22

*R. Usha*  
**Co ordinator**  
**Career and Counselling cell**  
**UGC**  
**Sri Paomavati Mahila Visvavidyalayan**  
**TIRUPATI - 617 602**

[funda drone - Go](#) X [android internshi](#) X [Web developmen](#) X [criteria-1 engine](#) X [APSSDC-Training](#) X [WhatsApp](#) X [APSSDC](#) X

[Not secure | engineering.apssdc.in](#)

**Andhra Pradesh State Skill Development Corporation (APSSDC)**  
 (Department of Skill Development & Training, Govt. of Andhra Pradesh)



[Home](#) [Forms](#) [Reports](#) [Logout](#)

Program wise report

Program >> Fundamentals Of Drones Technology - Online(2021-22) , Course >> Drone Technology

S.No.	Registration Id	Name	Email	Phone	Category	Payment	Edit	Action
1	1775003	Anjali	mungaerukalaanjali@gmail.com	8106423781	ST	-		
2	1775005	Putha Archana	puthaarchana@gmail.com	9177395839	OC	-		
3	1775011	Bolisetty Dharani	dharani0299@gmail.com	7330712041	BC-B	-		
4	1775029	Kovelakuntla Mounika	kovelakuntlamounika0@gmail.com	9640857110	SC	-		

Copyright © APSSDC

[Students \(2\).csv](#) [Students \(1\).csv](#) [WhatsApp Image...jpeg](#) [15625780\\_116591...jpg](#) [15676043\\_116589...jpg](#) [Show all](#)

10:37 JAVASR  
12-May-22

CATIA V5 - [Part1]

Start ENOVIA V5 VPM File Edit View Insert Tools Window Help

yz plane  
zx plane  
Axis Systems  
Geometrical Set.1  
Point.1  
PartBody  
Body.2

Profile

Constraint

Operation

Sketch tools

Start Point: H | 15.046mm | 36.349mm | 0mm | 0deg

User Selection Filter

Select a point or click to locate the start point

07:36

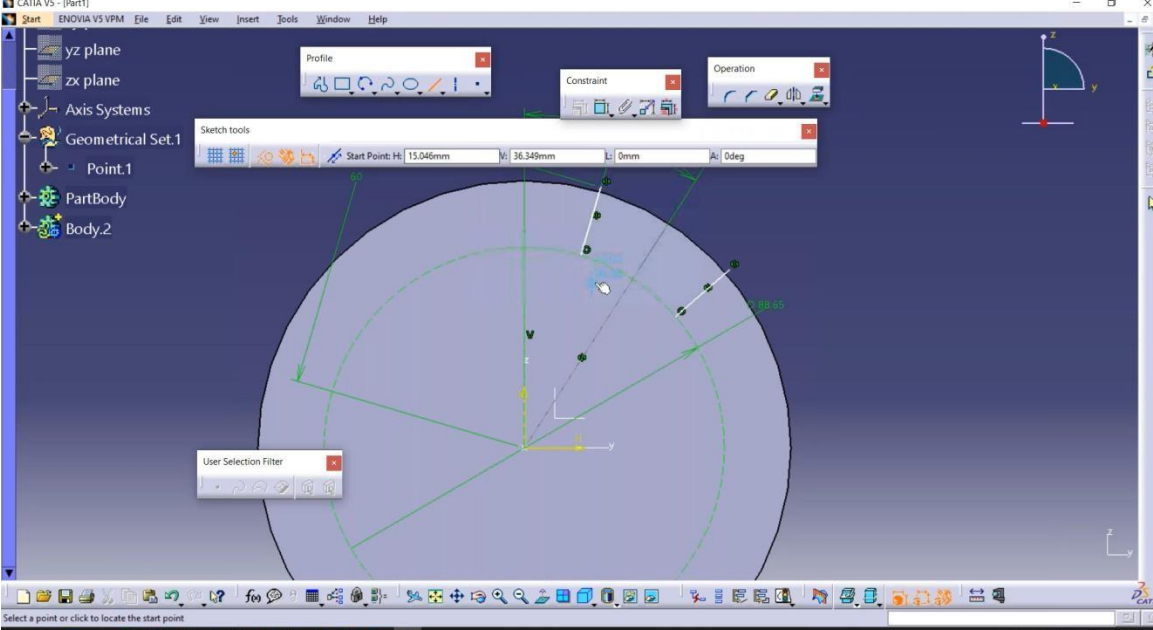

  
 Co ordinator  
 Career and Counselling cell  
 UGC  
 Sri Padmavati Mahila Viswavidyalayam  
 TIRUPATI - 517 502

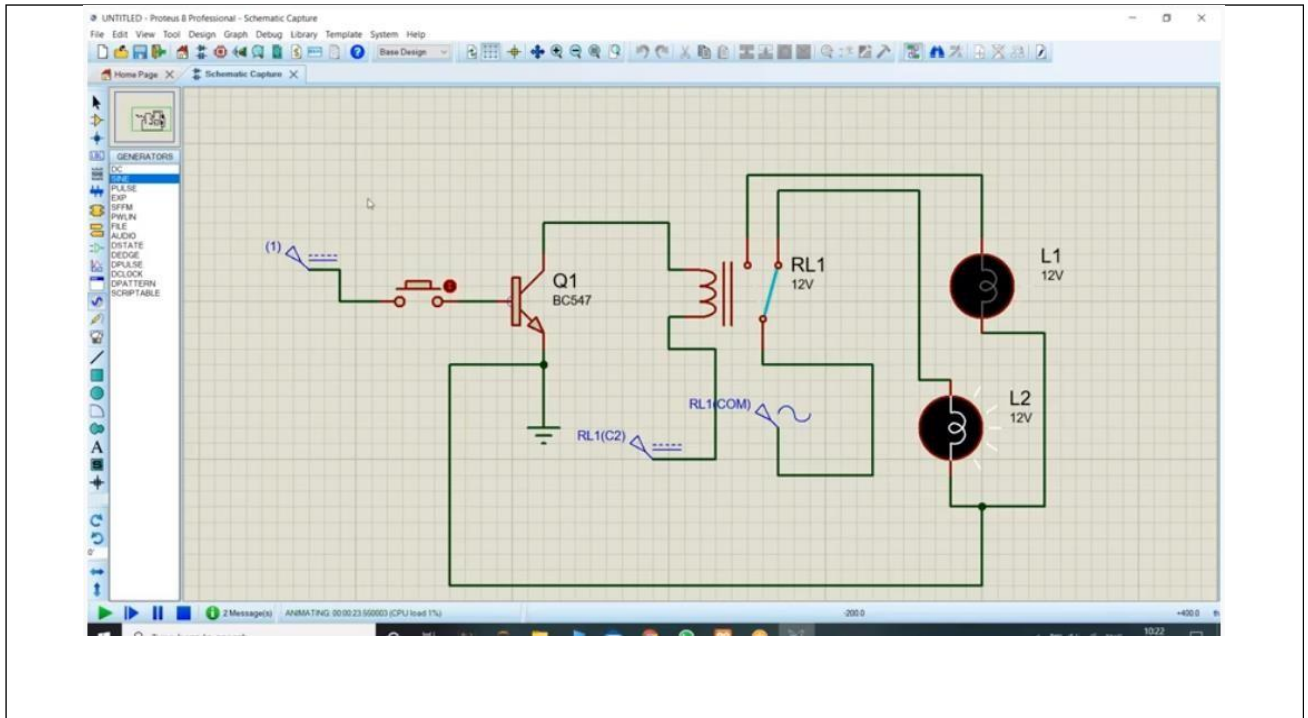

*R. Usha*  
Co ordinator  
Career and Counselling cell  
UGC  
Sri Padmavati Mahila Visvavidyalayam  
TIRUPATI - 517 502

<b>Program No</b>	10
<b>Name of the program</b>	Webinar on Career Guidance & Placement Skills to all B.Tech & P.G Students
<b>Date</b>	30 <sup>th</sup> May, 2021
<b>Venue</b>	Virtual
<b>240</b>	240
<b>Report</b>	Conducted a webinar on Career Guidance and Placement skills by Career Launcher to all the B.Tech& PG students on importance of Aptitude, Reasoning, and Arithmetic, Communication Skills, Verbal Reasoning, Digital skills elaborated on various opportunities and industry required skills.

**Placement Skills** CL KAUTILYA

**TOP 10 DIGITAL SKILLS COVETED BY EMPLOYERS**

Rank	Skill	2021	2020	
1	Digital Marketing	50%	44%	▲
2	Data Analysis	36%	40%	▼
3	Project Management	35%	43%	▼
4	Basic IT Support	35%	33%	▲
5	Data-Driven Decision Making	30%	32%	▼
6	Web/ App Design & Development	28%	31%	▼
7	Cybersecurity	27%	25%	▲
8	Governance, Risk Management & Personal Data Protection	24%	22%	▲
9	AI/ Machine Learning	22%	20%	▲
10	Robotic Process Automation	20%	17%	▲

zoom

Live chat

Top chat 240





Recording LIVE on YouTube

**Placement Skills** CL KAUTILYA

## TOP 10 DIGITAL SKILLS COVETED BY EMPLOYERS

Rank	Skill	2021	2020
1	Digital Marketing	50%	44% ▲
2	Data Analysis	36%	40% ▼
3	Project Management	35%	43% ▼
4	Basic IT Support	35%	33% ▲
5	Data-Driven Decision Making	30%	32% ▼
6	Web/ App Design & Development	28%	31% ▼
7	Cybersecurity	27%	25% ▲
8	Governance, Risk Management & Personal Data Protection	24%	22% ▲
9	AI/ Machine Learning	22%	20% ▲
10	Robotic Process Automation	20%	17% ▲

Video call participants: R. Usha, NS Reddy, Kautilya CL, Sony B

12:54 19%

**Placement Skills** CL KAUTILYA

## TOP 10 DIGITAL SKILLS COVETED BY EMPLOYERS

Rank	Skill	2021	2020
1	Digital Marketing	50%	44% ▲
2	Data Analysis	36%	40% ▼
3	Project Management	35%	43% ▼
4	Basic IT Support	35%	33% ▲
5	Data-Driven Decision Making	30%	32% ▼
6	Web/ App Design & Development	28%	31% ▼
7	Cybersecurity	27%	25% ▲
8	Governance, Risk Management & Personal Data Protection	24%	22% ▲
9	AI/ Machine Learning	22%	20% ▲
10	Robotic Process Automation	20%	17% ▲

Video call participant: Kautilya CL

**Live chat**

Top chat 240

- 12:26 pm Kareti anusha good afternoon sir
- 12:26 pm mounika naguru good afternoon sir
- 12:26 pm KUMMITHI VENKATALAKSHMIDEVI good afternoon sir
- 12:27 pm Chatla aruna good afternoon sir
- 12:28 pm A.Adilakshmi good afternoon mam....and ...sir...
- 12:29 pm Anusha Padarathi good afternoon sir
- 12:30 pm SUMA REDDY good afternoon sir
- 12:30 pm Anitha M gud afternoon sir
- 12:32 pm Sai Ram amsetty good afternoon sir

*R. Usha*  
 Co ordinator  
 Career and Counselling cell  
 UGC  
 Sri Padmavati Mahila Visvavidyalayam  
 TIRUPATI - 517 502

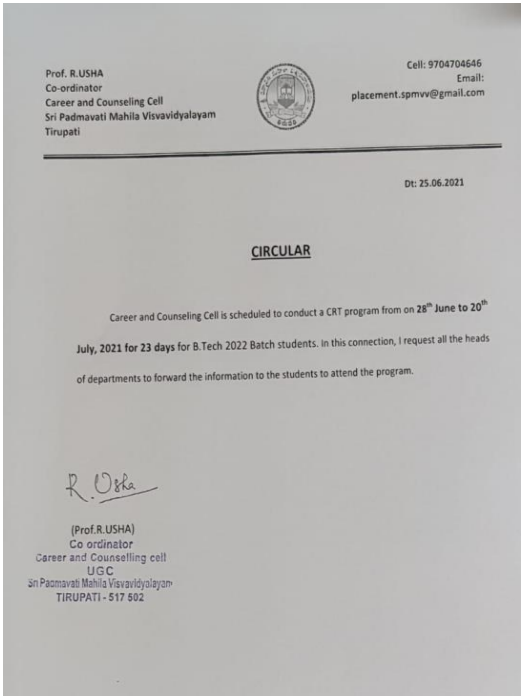

<b>Program No</b>	<b>11</b>
<b>Name of the program</b>	Virtual CRT Program
<b>Date</b>	June 28 <sup>th</sup> 2021 to 20 <sup>th</sup> July 2021
<b>Venue</b>	SoET,SPMVV
<b>Total No of Students</b>	305
<b>Report</b>	<p>Organised a 23 days virtual Company Recruitment Training Program for B.Tech final year students of 2022 batch by Six Phase, Coimbatore.</p> <p>The students are trained on the below mentioned topics:</p> <ol style="list-style-type: none"> <li>1. Aptitude</li> <li>2. Technical(C, Java,Osms)</li> <li>3. Verbal Ability</li> <li>4. Logical Reasoning</li> <li>5. Resume Writing</li> </ol> <p>The vendor has also conducted pre assessment and post assessment training.</p>
	

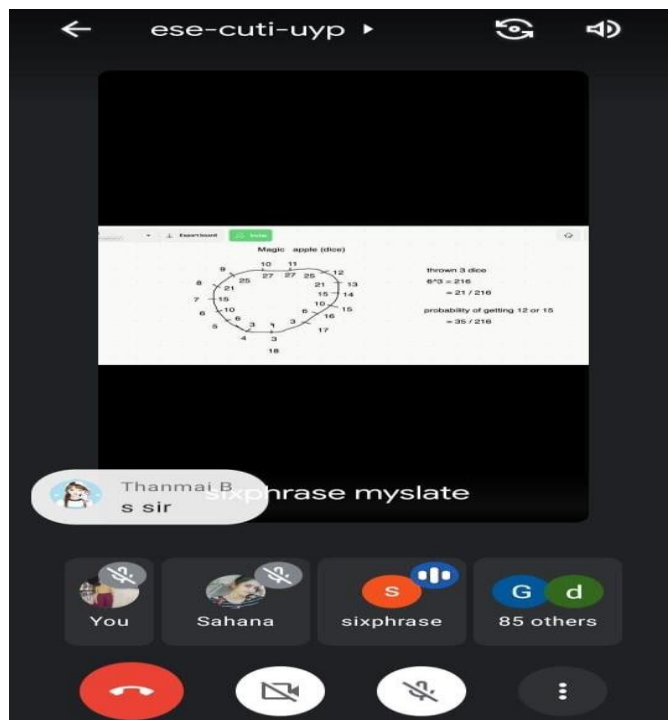

  
 Co ordinator  
 Career and Counselling cell  
 UGC  
 Sri Paomavati Mahila Visvavidyalayam  
 TIRUPATI - 617 602

<b>Program No</b>	<b>12</b>
<b>Name of the program</b>	CTS – Virtual Company Specific Training
<b>Date</b>	17 <sup>th</sup> September to 21 <sup>st</sup> September, 2021
<b>Venue</b>	Virtual
<b>Total No of Students</b>	141
<b>Report</b>	<p>Organised Cognizant company specific training program for final year B.Tech students of Batch 2022 through virtual mode.</p> <p>The topic includes:</p> <p><b>TIPS FOR JOB INTERVIEWS TO STUDENTS :</b></p> <p>There are two aspects to keep in mind as an interviewee, first to find out how well the job and the organization suits you; second and more important goal is how to get selection. The following tips, guidelines and insight to interviews may help you to put in proper efforts and performance to attain the above goals.</p> <p><b>1. SELF ASSESSMENT</b></p> <p>The first preparation that you can make for an employment interview is to give some serious thought about yourself by taking stock of your needs, interests and preferred job outcomes. Also, take stock of your strengths and weaknesses. Reflect on your goals and ambitions. A good starting point would be to prepare a detailed Resume, a comprehensive and well-organized record of your accomplishments. As you prepare it, you will have to review your academic qualifications, knowledge, skills, experiences and achievements.</p> <p><b>2. JOB ANALYSIS</b></p> <p>The next step is to analyze the job to find out whether the organization and the job provides you the right opportunities keeping in mind your personal capabilities as well as your career goals. Listed below are certain qualities, which are generally assessed in interviews with the priorities and</p>

weightages, varying with the job.

### **Academic**

- Good scholastic record
- Preparation for interview
- Formulated long range goals & objectives

### **Personality**

- Enthusiasm
- Self confidence
- Pleasant personality
- Emotional stability
- Poise in the interview
- Aggressiveness & Initiative
- Efficiency
- Moral standards
- Humility
- Good health
- Extracurricular activities

### **Communication & Leadership qualities**

- Communication skills
- Writing skills
- Leadership potential
- Managerial skills
- Interest in people

### **Preparation for the Interview**

#### 4.1 Familiarity with the interview process

You will be more confident in the interview, if you prepare well in advance for the type of questions and the areas of specialization that are likely to be tested in the interviews. Personnel selection procedures vary

greatly depending on the organization, the type of job and level of the job. Generally, the job selection is made by anyone or a combination of the following.

- A. Written Test (aptitude test, Logical Reasoning test, Quantitative test and Technical Test)
- B. Technical Test (Programming Round)
- C. SWAR Round (Communication proficiency)
- D. Group Discussions
- E. Technical Interview
- F. Psychometric Test
- G. HR Interview

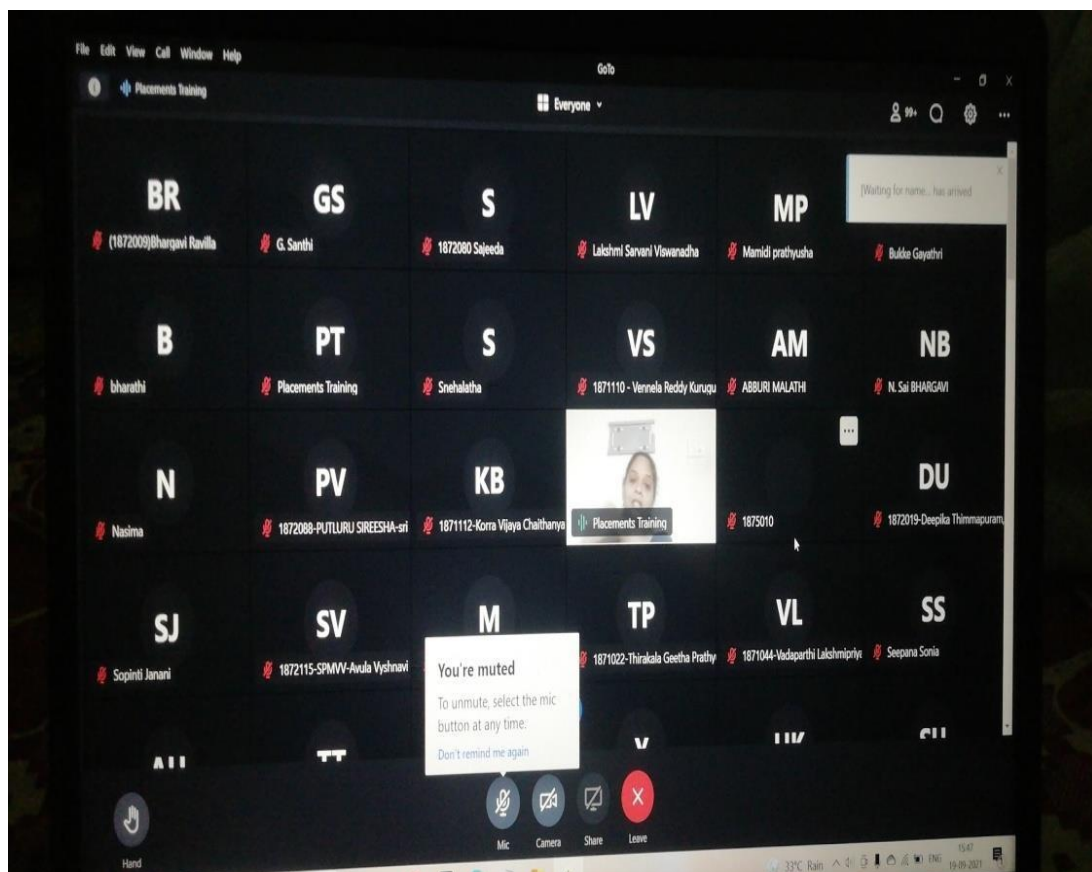

*R. Usha*  
Co ordinator  
Career and Counselling cell  
UGC  
Sri Pramava Mahila Visvavidyalayam  
TIRUPATI - 517 502

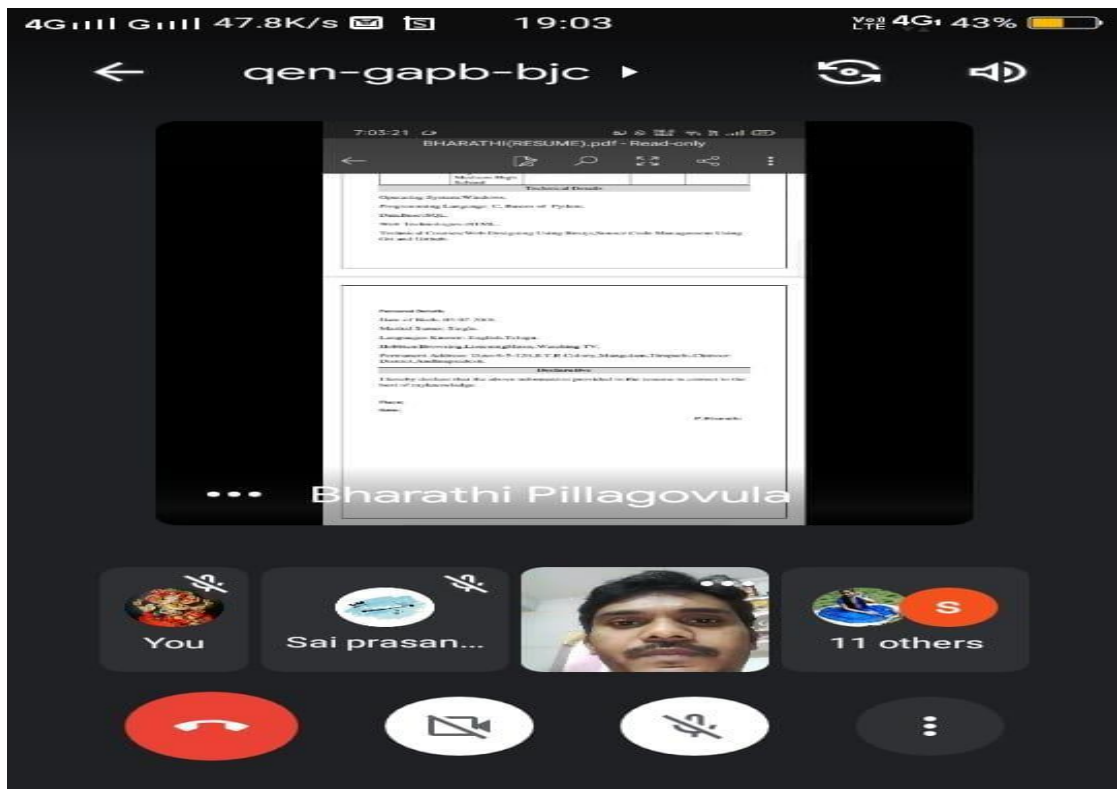
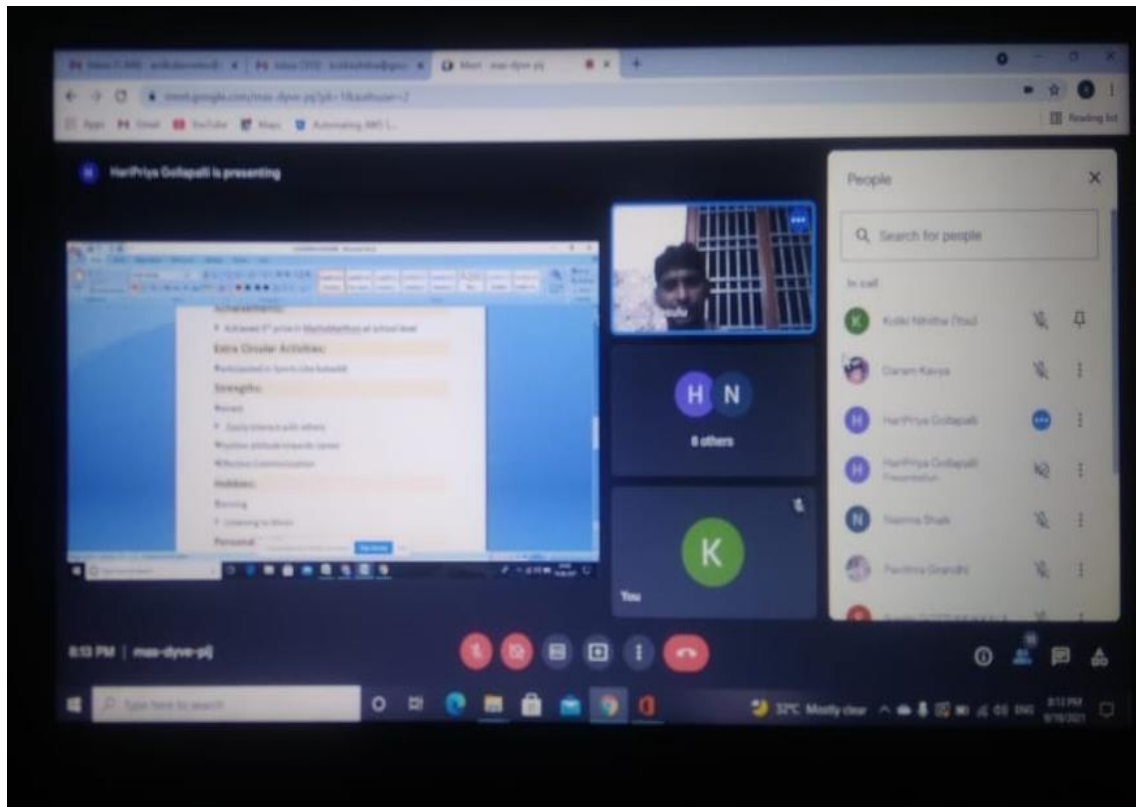





*R. Usha*  
Co ordinator  
Career and Counselling cell  
UGC  
Sri Padavati Mahila Visvavidyalayan  
TIRUPATI - 517 502

<b>Program No</b>	<b>13</b>
<b>Name of the program</b>	Resume Building And Technical Training
<b>Date</b>	25 <sup>th</sup> September to 3 <sup>rd</sup> October, 2021
<b>Venue</b>	Virtual
<b>Total No of Students</b>	180
<b>Report</b>	<p>Organised a program on Resume Building and Technical Training For Final Year B.Tech Students.</p> <p><b>Topics for Technical Training Program</b></p> <ul style="list-style-type: none"> <li>❖ Structure of C Program</li> <li>❖ 2. Pre-Processing (Macros, Header Files etc)</li> <li>❖ 3. Comments main function, Output function – printf, Input function – scanf compilation and Execution of a C program</li> <li>❖ 4. Data types, variables and constants</li> <li>❖ Operators and Type of operators</li> <li>❖ Selection Statements (if and switch)</li> <li>❖ Loop statements (while, do-while and for)</li> <li>❖ Nested for Loops</li> <li>❖ Why arrays, Memory Allocation, Indexing</li> <li>❖ Array Operations</li> <li>❖ Pointers ,accesing pointer variables and creation</li> <li>❖ Pointer to pointer, void pointer, assignment on pointers</li> <li>❖ Strings and string functions</li> <li>❖ Function, types of calling, function arguments, need of a function.</li> <li>❖ Problems on arrays</li> <li>❖ Model questions of CTS, Wipro etc..</li> <li>❖ 17. Data Structures</li> <li>❖ 18. Basic DBMS</li> </ul>

  
**Co ordinator**  
**Career and Counselling cell**  
**UGC**  
**Sri Padmavati Mahila Visvavidyalayam**  
**TIRUPATI - 517 502**

<b>Program No</b>	<b>14</b>
<b>Name of the program</b>	TCS & Wipro Company specific training
<b>Date</b>	14th to 16th October 2021
<b>Venue</b>	Virtual
<b>Total No of Students</b>	200
<b>Report</b>	<p>TCS &amp; Wipro Company specific training for final Year B.Tech Students from 14th to 16th October 2021.</p> <p>Training sessions and video recordings that provide inquiry-based knowledge to the students. Campus trainings and courses that have been detailed with latest study material and teaching patterns. Students have been trained on soft-skills and the skills required at the job market with hands on experience of the job environment.</p> <p>Objectives of the program:</p> <ul style="list-style-type: none"> <li>▪ 3 days of in-depth company specific Interview preparation includes technical skills shall surely make the students understand the exact pattern of the expectations from the company.</li> <li>▪ Students will gain enormous confidence and clarity over the interview pattern and questions and materials to enhance their technical &amp; psychometric skills and to attend their interviews in such a way.</li> </ul>

  
**Co ordinator**  
**Career and Counselling cell**  
**UGC**  
**Sri Padmavati Mahila Visvavidyalayan**  
**TIRUPATI - 517 502**

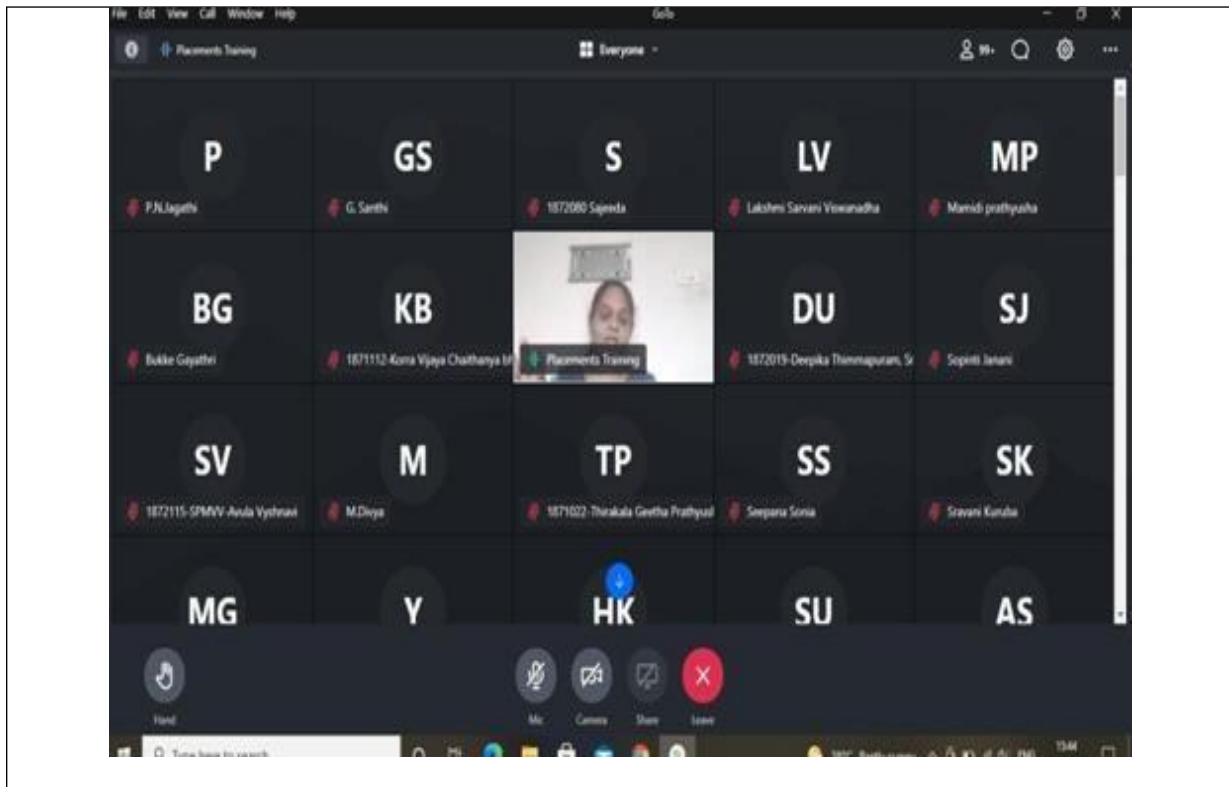

*R. Usha*  
Co ordinator  
Career and Counselling cell  
UGC  
Sri Padmavati Mahila Visvavidyalayan  
TIRUPATI - 517 502

<b>Program No</b>	15
<b>Name of the program</b>	Career Opportunities in University Malaysia
<b>Date</b>	04th December, 2021
<b>Venue</b>	Saaveri Seminar Hall, SPMVV
<b>Total No of Students</b>	80
<b>Report</b>	A one day session on Career Opportunities in University Malaysia is organized. Resource person Dr. Mohammed Arifullah, faculty of Agro Industry and Natural Resources (FASA) Kelantan, Malaysia addressed the Life Sciences students regarding career opportunities in Malaysia.





**Resource Person:** Dr. Mohammed Arifullah







## Distribution of Broucher



*R. Usha*  
 Co ordinator  
 Career and Counselling cell  
 UGC  
 Sri Padmavati Mahila Visvavidyalayam  
 TIRUPATI - 617 602

<b>Program No</b>	<b>16</b>
<b>Name of the program</b>	Induction program
<b>Date</b>	13th December, 2021
<b>Venue</b>	Online
<b>Total No of Students</b>	57
<b>Report</b>	<p>Induction program by Shriram Life Insurance through Online, for M.Com Students. About 57 students attended the program. and 32 students selected as interns in Shriram Life Insurance.</p> <p>The internship would entail the following-</p> <ul style="list-style-type: none"> <li>• Training on Protection and Investment</li> <li>• Digital Marketing</li> <li>• Live projects</li> <li>• One-to-one mentoring</li> <li>• Internship certificate</li> <li>• Online sales</li> </ul> <p><b><u>Key Skills</u></b></p> <ul style="list-style-type: none"> <li>• Incumbent should be willing to work in a target-based approach with a focus on new customer acquisition and lead generation</li> <li>• Should have sound knowledge of the Digital business ecosystem.</li> <li>• Candidates should be self-motivated, Tech-savvy understanding of Powerpoint and Excel will be useful.</li> <li>• Candidate should have expertise in customer relationship management and business development capabilities</li> <li>• Strong leadership qualities with good communication, interpersonal &amp; presentation skills</li> </ul>

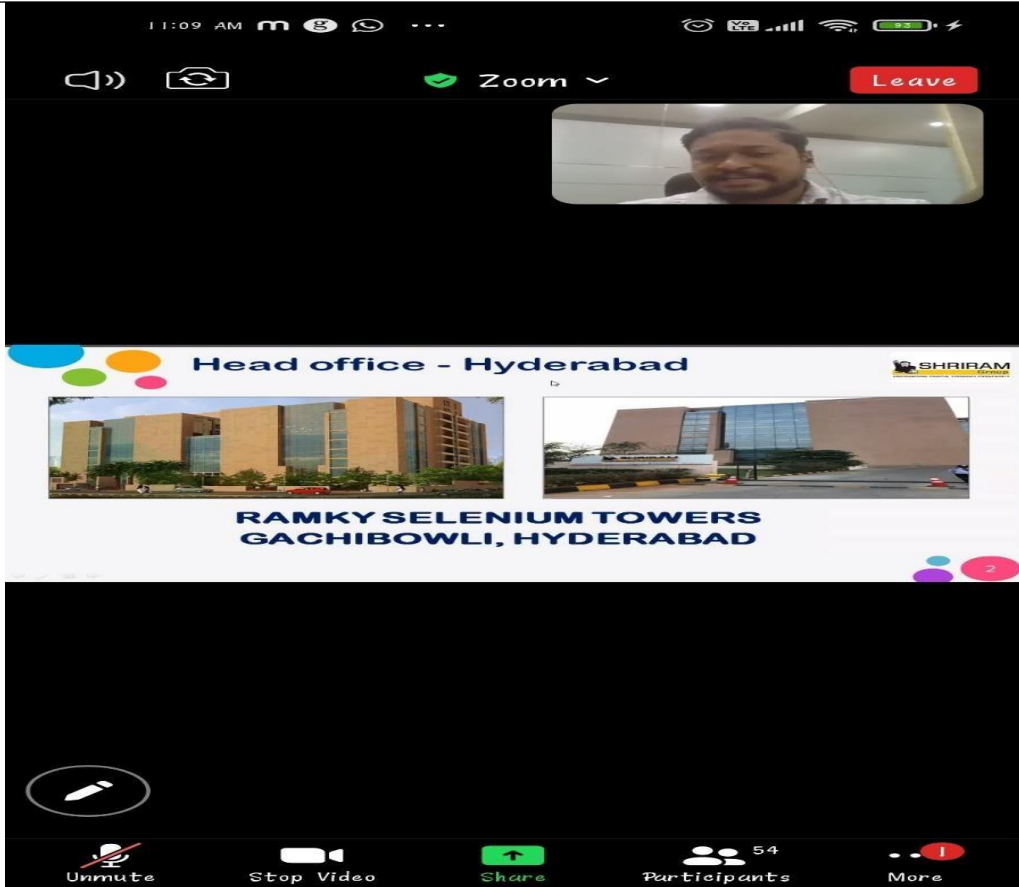

*R. Usha*  
Co ordinator  
Career and Counselling cell  
UGC  
Sri Padmavati Mahila Visvavidyalayam  
TIRUPATI - 517 502

<b>Program No</b>	<b>17</b>
<b>Name of the program</b>	Workshop on Soft skills
<b>Date</b>	20th Dec To 24th December 2021
<b>Venue</b>	MCA Department
<b>Total No of Students</b>	120
<b>Report</b>	<p>Naandi Foundation in association with APITA (Andhra Pradesh Information Technology Academy) conducted five days training program on employability skills from 20/12/2021 to 24/12/2021. It was a thorough and well-organized training program with right blend of Soft skills, Life skills, Interview skills and Communication skills.</p> <p>In this entire training program, there is significant change in the students in terms of Body language, Professional Grooming. Students have learnt the Importance of English, Professional Communication, Interview readiness, exploring job opportunity, Goal setting and Time Management, Professional ethics. Presenting a project, Group Discussion sessions helped the students immensely and prepared them well for the future employment opportunities. As all the topics facilitated enabled students to improve their confidence levels. Various individual and group presentations removed stage fear from students.</p>

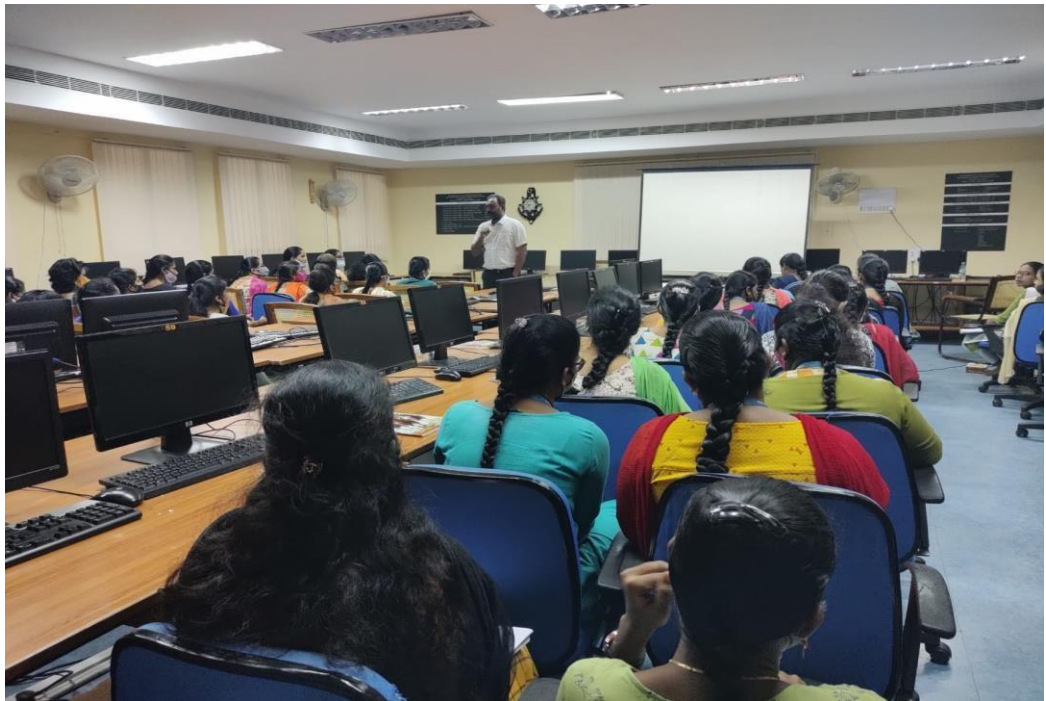

*R. Usha*  
Co ordinator  
Career and Counselling cell  
UGC  
Sri Padmavati Mahila Visvavidyalayan  
TIRUPATI - 517 502





*R. Usha*  
Co ordinator  
Career and Counselling cell  
UGC  
Sri Padmavati Mahila Visvavidyalayam  
TIRUPATI - 517 502



*R. Usha*  
Co ordinator  
Career and Counselling cell  
UGC  
Sri Padmavati Mahila Viswavidyalayan  
TIRUPATI - 517 502

<b>Program No</b>	<b>18</b>
<b>Name of the program</b>	CSRBOX – Workshop on Road Safety
<b>Date</b>	23rd December, 2021.
<b>Venue</b>	Online
<b>Total No of Students</b>	87
<b>Report</b>	<p>Organised a workshop on The WRONG SIDE OF THE ROAD Initiative is also a part of a global effort under Decade of Action for RoadSafety 2020 – 30 by the United Nations to empower Young college going students, with the right set of life skills in an interactive learning format. The program entails a <b>30 to 45 Mins E-workshop</b>, consisting of an <b>interactive life experiences &amp; live engagement</b> with the participants. This course aims to create awareness about the risks of Rash driving, over speeding and Anti Drink and Drive. It tackles key themes and focuses on a) Preventive education – Impaired driving b) RoadSafety education c) Positive Behavioral change</p> <p>CSRBOX are facilitating the WRONG SIDE OF THE ROAD Initiative by provisioning these workshops for the age group of <b>18+ years, Pan India.</b></p>

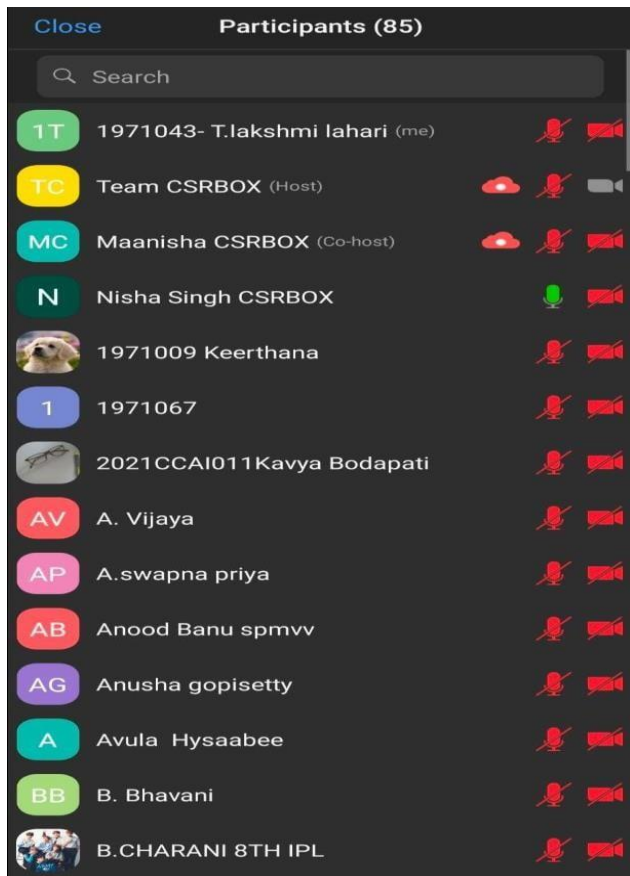
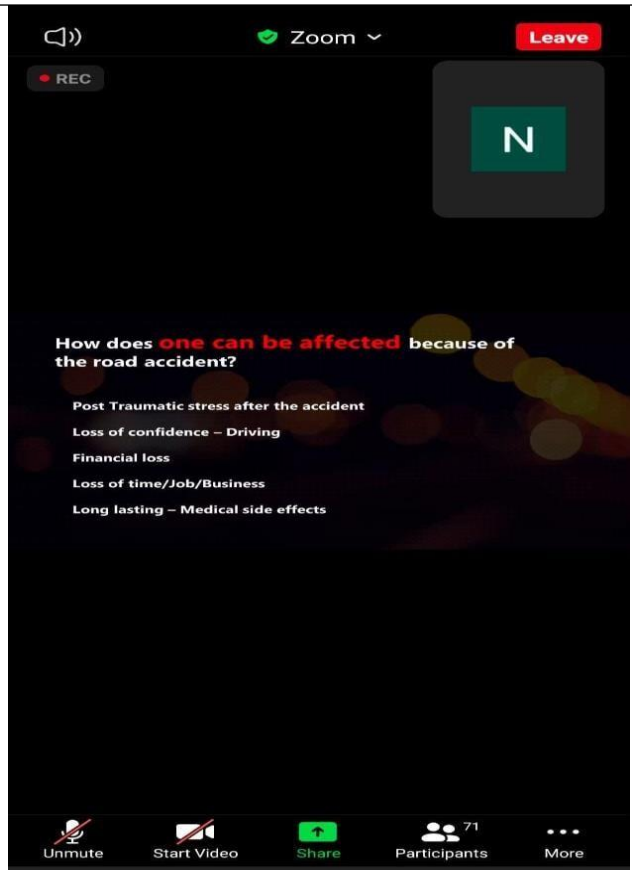

*R. Usha*  
 Co ordinator  
 Career and Counselling cell  
 UGC  
 Sri Padmavati Mahila Visvavidyalayam  
 TIRUPATI - 517 502

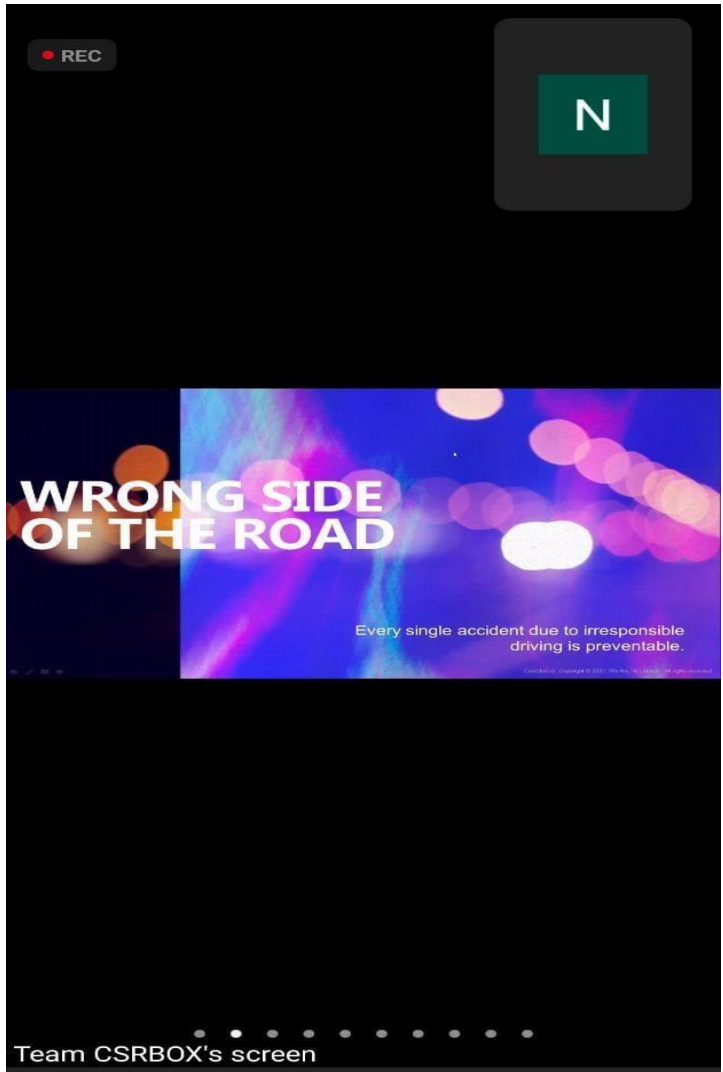

*R. Usha*  
Co ordinator  
Career and Counselling cell  
UGC  
Sri Paomavati Mahila Visvavidyalayam  
TIRUPATI - 517 502



Zoom

Leave

REC

N

Have You ever **RASH DRIVE** or **EXCEED THE SPEED LIMIT** or **BROKE A ROAD SAFETY PROTOCOL JUST FOR FUN** or **ADVENTURE?**



Unmute Start Video Share Participants 86 More

*R. Usha*  
Co ordinator  
Career and Counselling cell  
UGC  
Sri Padmavati Mahila Visvavidyalayam  
TIRUPATI - 517 502

<b>Program No</b>	<b>19</b>
<b>Name of the program</b>	Induction program by Shriram Life Insurance through online, students from MBA department selected as interns in Shriram Life Insurance.
<b>Date</b>	28th December, 2021
<b>Venue</b>	Online
<b>Total No of Students</b>	67
<b>Report</b>	<p>Induction program by Shriram Life Insurance through Online, students from MBA department participated in the program 32 students selected as interns in Shriram Life Insurance.</p> <p>The internship would entail the following-</p> <ul style="list-style-type: none"> <li>• Training on Protection and Investment</li> <li>• Digital Marketing</li> <li>• Live projects</li> <li>• One-to-one mentoring</li> <li>• Internship certificate</li> <li>• Online sales</li> </ul> <p><b><u>Key Skills</u></b></p> <ul style="list-style-type: none"> <li>• Incumbent should be willing to work in a <b>target-based</b> approach with a focus on new customer acquisition and lead generation</li> <li>• Should have sound knowledge of the Digital business <b>ecosystem</b>.</li> <li>• Candidates should be self-motivated, <b>Tech-savvy</b> understanding of <b>Powerpoint and Excel</b> will be useful.</li> <li>• Candidate should have expertise in customer relationship management and business development capabilities</li> <li>• Strong leadership qualities with good communication, interpersonal &amp; presentation skills</li> </ul>

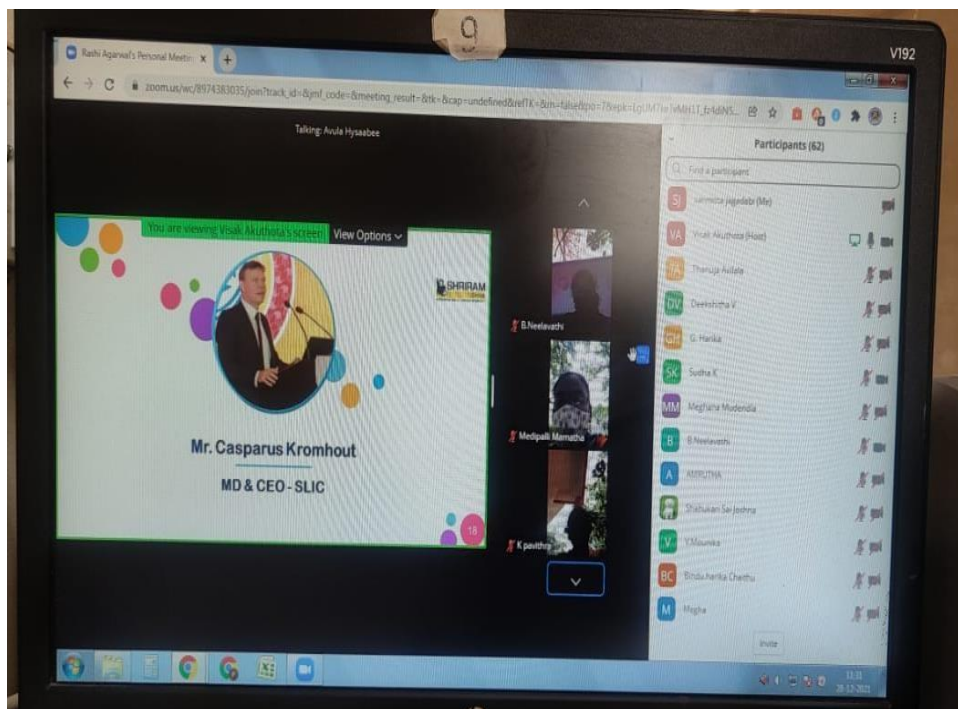
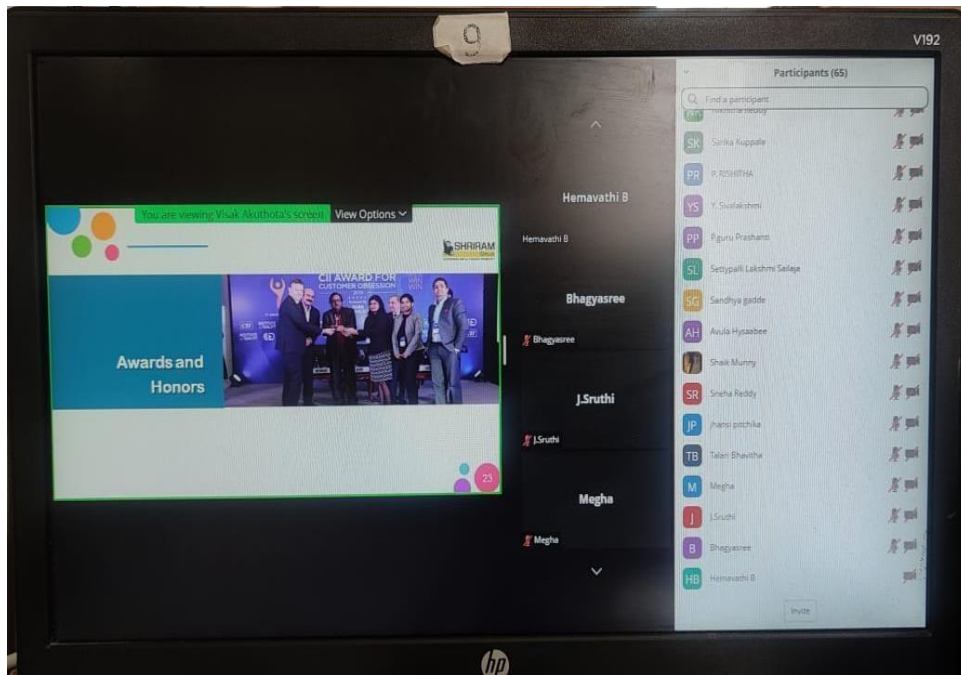

*R. Usha*  
 Co ordinator  
 Career and Counselling cell  
 UGC  
 Sri Paomavati Mahila Visvavidyalayan  
 TIRUPATI - 517 502

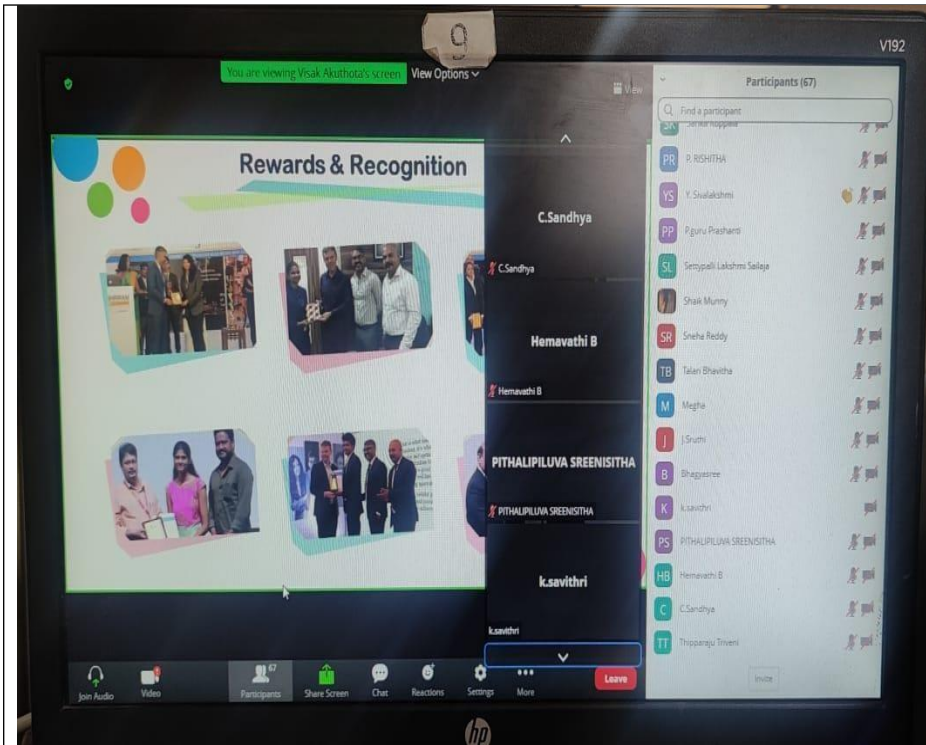

*R. Usha*  
Co ordinator  
Career and Counselling cell  
UGC  
Sri Padmavati Mahila Visvavidyalayan  
TIRUPATI - 517 502